

I: Modern comfort.

Ischia	10
Talia	14
Camillo	18
Moire	22
Graco	26
Beat	32
Aura	36
Dafne	40
Cloé	44
Kyros	48
Ariell	56
Hermas	60
Melissa	64
Zenas	68
Cornelia	72
Orfeo	76
Leandro	80
Lucrezia	84
Sommier	98
Calliope	100
Urania	106
Sebastian	110
Ariston	116
Tereo	122
Leandro	126
Dolce Vita	130
Altea	132
Zuma	136
Olimpia	140

II: Complements & technical infos.	146
---	------------



Charme
OFFICINA INTERIOR

“ A new brand —with a strong background ”

Charme nasce dalla perfetta sintonia tra tradizione e contemporaneità, da sapienti ed artigiane mani che cuciono pregiati e ricercati tessuti. Il gusto per il Made in Italy e la capacità di interpretare e rendere reale ogni progetto, fanno di Charme il brand ideale per un cliente raffinato ed attento allo stile, che non segue le mode ma che desidera un'eleganza senza tempo.

Charme provient de l'harmonie parfaite entre tradition et modernité, des mains sages et artisanales qui fabriquent des tissus fins et recherchés. Le goût pour le Made in Italy et la capacité d'interpréter et de réaliser n'importe quel projet, font de Charme la maison idéale pour un client sophistiqué et attentif au style, qui ne suit pas les modes, mais désire une élégance éternelle.

Charme was born from the perfect harmony between tradition and modernity, by skilled and artisanal hands that sew fine and high quality fabrics. The taste for the Made in Italy and the ability to interpret and realize any kind of project, make of Charme the ideal brand for a sophisticated and stylish customer, who doesn't follow fashions but searches a timeless elegance.

Charme nace de la perfecta armonía entre tradición y contemporaneidad, con expertos artesanos que cosen selectos tejidos muy preciados. El gusto por el Made in Italy y la capacidad para interpretar y hacer realidad cada proyecto, hace de Charme la marca ideal para un cliente refinado atento al estilo, que no sigue modas, pero requiere elegancia atemporal.

Charme来源于传统与现代的完美结合，用精美手工来缝合秀雅与精致的布料。对意大利制造工艺的赏析和完美实现每个项目是Charme一贯的特点和实力。Charme 是那些注重风格、不盲目追随趋势，并追求永恒优雅的客户心中的理想品牌。

ديليقتلا نيب تدلو مراه
نييفرحال لبق نم رصاعملاو
تشمقالا نوكيحي نيزلا
ققوهرملاو قليمجالا
قردقلا اهدل قيلاطيا ةعانص
لك لعجو ريسفت ىلع
قمالعال اعاطع او يقيقح عورشم
نوبزلل قيلاشملا قيراجتلا
بولسالال ىلا هابتنالال او روطتم
لب قضيوملا عبتى ال يزللا
قدلاخ ققانلا

Charme появилась благодаря гармоничному сочетанию традиций и современности, это результат работы умелых ремесленных рук, которые создают и работают с изысканными материалами. Производство Made in Italy и способность реализовать любой проект, делают Charme идеальным брендом для тех клиентов, которые любят изысканность и стиль, которые не идут за модой, а предпочитают элегантность, над которой не властно время.



“__ Hand made in Italy certified”

Ogni attimo che trascorriamo nella nostra casa è fatto di piccoli e quotidiani gesti che ci fanno stare bene, di forme e colori armoniosi, di morbidezza e linee che rendono unico il nostro dormire e i momenti di relax.

La nostra collezione comprende letti imbottiti, poltrone, sedie, divani, lampade e accessori, eleganti e confortevoli parure, completamente personalizzabili per donare armonia, calore e personalità ad ogni ambiente della casa.

Le materie prime di qualità, la continua ricerca e selezione di nuovi tessuti e pelli, la cura dei particolari, la capacità di interpretare le tendenze del momento, ci rendono capaci di realizzare ogni progetto e di assecondare sempre le richieste dei nostri clienti.

Ecco perché Chaarme è il brand ideale per soddisfare i vostri desideri e arredare la casa con stile ed eleganza.

Each moment we spend in our homes is a collection of daily little things that give us a sense of wellness, of harmonious shapes and colors, of soft lines which make unique our sleeping and relax.

Our collection is composed by upholstered beds, armchairs, chairs, sofas, lamps and other accessories, elegant and comfortable bed sheets, totally customizable to give harmony and personality to every room.

The high-quality raw materials, the continuous research and selection of fabrics and leathers, our never-fading attention for details, the desire to meet our clients' requests and the ability to interpret trends, make us capable to realize each project.

For all that reasons, Chaarme is the ideal brand to satisfy your desires and furnish your home with a touch of style and elegance.

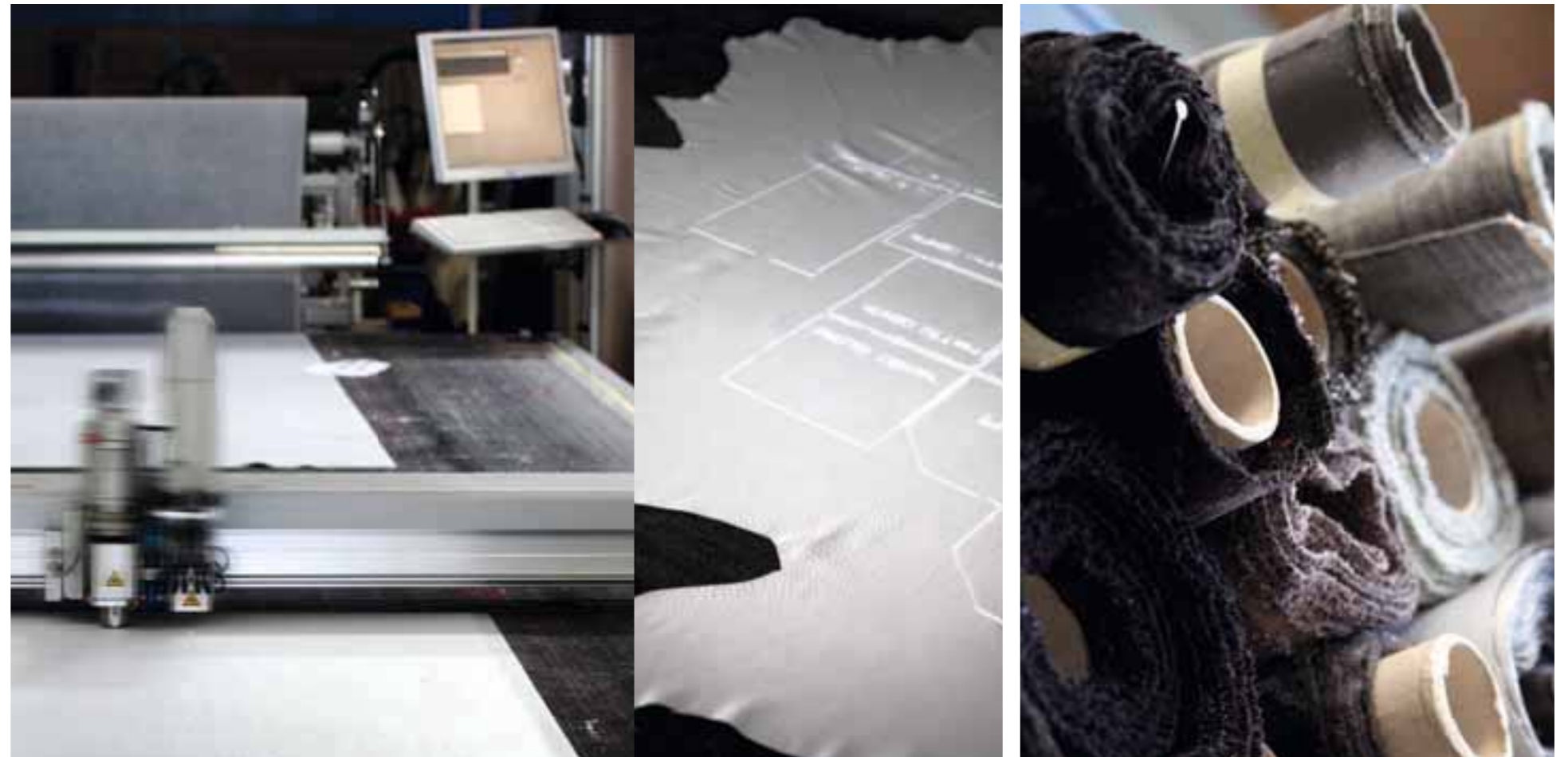

“ I Charme

contemporary style :
beds and complements ”

Ischia

SFODERABILE
REMOVABLE LINING

Ischia: letto sfoderabile, tessuto Dubai col. 1001. Testata con cuscini imbottiti e caratterizzata da una cucitura centrale. Giroletto lineare che scopre degli eleganti ed essenziali piedini in legno, color Wengé. **Cruz:** tavolino con struttura in metallo dal disegno geometrico irregolare e ripiano in marmo Imperador. **Panca Ischia:** comoda e pratica panca scendiletto con struttura in legno, rivestita in tessuto Dubai col. 1001. **Astrid:** poltroncina di design, con basamento in legno di faggio verniciato.

Ischia: bed with removable cover upholstered in Dubai col. 1001. Headboard cushions characterized by a central seam. Linear bed frame which discover elegant wooden legs with modern design, wood finish col. Wengé. **Ischia bench:** practical bench with wood structure, upholstered in fabric Dubai col. 1001. **Cruz:** bedside table with a geometrical metallic structure and table top in Imperador marble. **Astrid:** design's armchair with a steel body structure, entirely molded cold polyurethane foam.



Ischia

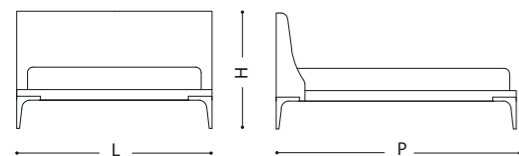

Bed dimensions (cm)
L: 108 · 138 · 158 · 171 · 188 · 198 · 211
P: 216 · 219
H: 104



Ischia: particolari della lavorazione in tessuto e del piede curvato.

Ischia: details about the cover and the multilayered wood feet characterized by a particular curve.

Talia

SFODERABILE
REMOVABLE LINING



Talia: letto sfoderabile, tessuto Dhely col. 03 con cuscini testata in tessuto Madrid col. G108. Testata con cuscini removibili senza sfoderare il letto. Piedini quadro finitura alluminio. Disponibile anche con vano contenitore. **Parentesi:** pouff in lino Tropea col. 0516. **Venus:** poltroncina in tessuto Barcellona col. 12.

Talia: Bed with removable cover upholstered in Dhely fabric, colour 03 with headboard cushions made of Madrid fabric, colour G108. The headboard cushions can be removed without removing the bed upholstery. Aluminium-finished square feet. Available also with a storage unit. **Parentesi:** Pouffe upholstered in Tropea linen, colour 0516. **Venus:** Small armchair upholstered in Barcellona fabric, colour 12.

Talia

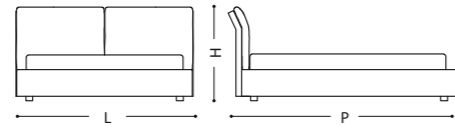

Bed dimensions (cm)
L: 114 - 144 - 164 - 177 - 184 - 194 - 204 - 217
P: 235 - 238
H: 95



Venus: Confortevole poltrona sfoderabile, in tessuto Barcellona col.12 e struttura tinta noce.

Venus: Comfortable armchair with removable cover in Barcelona fabric, colour 12, and walnut-stained frame.



Camillo

SFODERABILE
REMOVABLE LINING



Camillo: letto sfoderabile, in tessuto Milano col. 01. Dalle linee avvolgenti, caratterizzato da due cuscini morbidi e da un sinuoso giroletto. Disponibile anche con vano contenitore. Coordinato in leggero cotone e morbidi cuscini dalle diverse forme e cuciture in contrasto.
Calypso: Confortevoli e pratici pouff in lino Tropea col. 524 e in tessuto Dhely col. 04.
Cubolux: comodino ideale per tenere a portata di mano libri o riviste, è fornito di una comoda luce interna.

Camillo: Bed with removable cover upholstered in Milano fabric, colour 01. It is characterised by an enveloping line, two soft cushions and a winding bedframe. Available also with a storage unit. Light cotton bedding set with soft cushions in various shapes and contrasting colour seams.
Calypso: Comfortable and practical pouffes upholstered in Tropea linen, colour 524 and in Dhely fabric, colour 04
Cubolux: The ideal bedside table to have books or magazines within reach, it is fitted with a useful light inside.

Camillo



Cubolux: comodino ideale per tenere a portata di mano libri o riviste, è fornito di una comoda luce interna.

Cubolux: The ideal bedside table to have books or magazines within reach, it is fitted with a useful light inside.

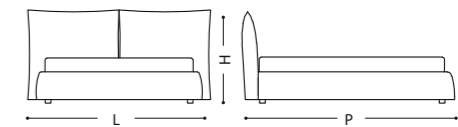

Bed dimensions (cm)
L: 128 · 158 · 178 · 191 · 198 · 208 · 218 · 231
P: 232 · 235
H: 100

“__Cubolux
bedside table”

Moire

SFODERABILE
REMOVABLE LINING

Moire: letto sfoderabile, in lino Tropea col. 501. Eleganza e gusto conferiti dal lino e da delicati particolari pinzati a ricamo su testata e angoli del giroletto (nella foto ricamo tipo America). Disponibile anche con vano contenitore.

Moire: Bed with removable upholstery cover in Tropea linen, colour 501. Elegance and taste are conferred by the linen fabric and by the delicate details embroidered on the headboard and on the corners of the bed frame (in this picture, America-style embroidery). Available also with a storage unit.



Moire

Moire: particolare del ricamo sulla testata e sul giroletto, personalizzabile con varie cuciture.

Moire: A detail of the embroidery on the headboard and the bed frame, it can be customised with various seams.

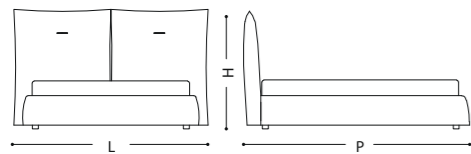

Bed dimensions (cm)
L: 127 · 157 · 177 · 190 · 197 · 207 · 217 · 230
P: 235 · 238
H: 132

Dolce Vita

Dolce Vita: poltrona dalle linee sinuose e confortevoli, in velluto Luxor col. E020. Adatta a tutti gli ambienti della casa, rimane un must senza tempo.

Dolce Vita: Winding and comfortable lines upholstered in Luxor velvet, colour E020. A timeless must-have that fits well in any room of the house.



Graco: Letto sfoderabile, in lino Tropea col. 504. Il rivestimento del giroletto è a balza con eleganti spacchi laterali. La testata è personalizzabile con le proprie iniziali. Disponibile anche con vano contenitore.

Graco: Bed with removable upholstery cover in Tropea linen, colour 504. The bed frame is upholstered with a flounce and elegant side vents, while the headboard can be customised with the customer's initial letters. Available also with a storage unit.





Graco

Il ricamo sulla testata, se richiesto, è personalizzabile.

If required, the embroidery on the headboard can be customised.

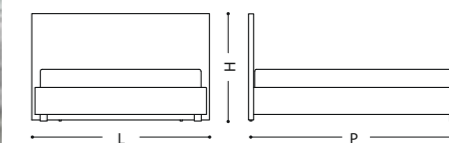

Bed dimensions (cm)
L: 108 · 138 · 158 · 171 · 178 · 188 · 198 · 211
P: 213 · 216
H: 110

Loto

Loto: comò e settimanale con finitura col. bianco laccato opaco.

Loto: 3-drawer chest and 6-drawer narrow chest with a matt white lacquer finish.



Provenza: comodino finitura col. bianco laccato opaco.

Provenza: Bedside table with mat lacquered white finish.

Beat

SFODERABILE
REMOVABLE LINING

Beat: letto moderno completamente sfoderabile, caratterizzato da una testata lineare, rivestito in tessuto Cannes col. 23 e personalizzabile con nervetto colorato. L'attenzione viene catturata dai piedini con finitura in acciaio. **Jane:** sedia con struttura in legno di faggio dalle linee sinuose e morbide, perfetta per ambienti sobri e raffinati. Qui proposta con rivestimento in tessuto Coimbra col. 14. **Vela:** tavolino con struttura in metallo verniciato bianco, e caratterizzato da un piano d'appoggio dalla forma pentagonale. **Marte:** lampada da terra con struttura in metallo verniciato bianco con un originale paralume dalla forma geometrica.

Beat: bed with removable cover in Cannes fabric col. 23, characterized by a simple and linear headboard, customizable with colour piping. The attention is caught by the feet with silver finish. **Jane:** chair with beechwood structure with an elegant design, perfect for. Upholster in Coimbra fabric col. 14. **Vela:** bedside table with a white lacquered metallic structure. Table top with a pentagonal shape. **Marte:** floor lamp with a white lacquered metallic structure and a geometrical lampshade.

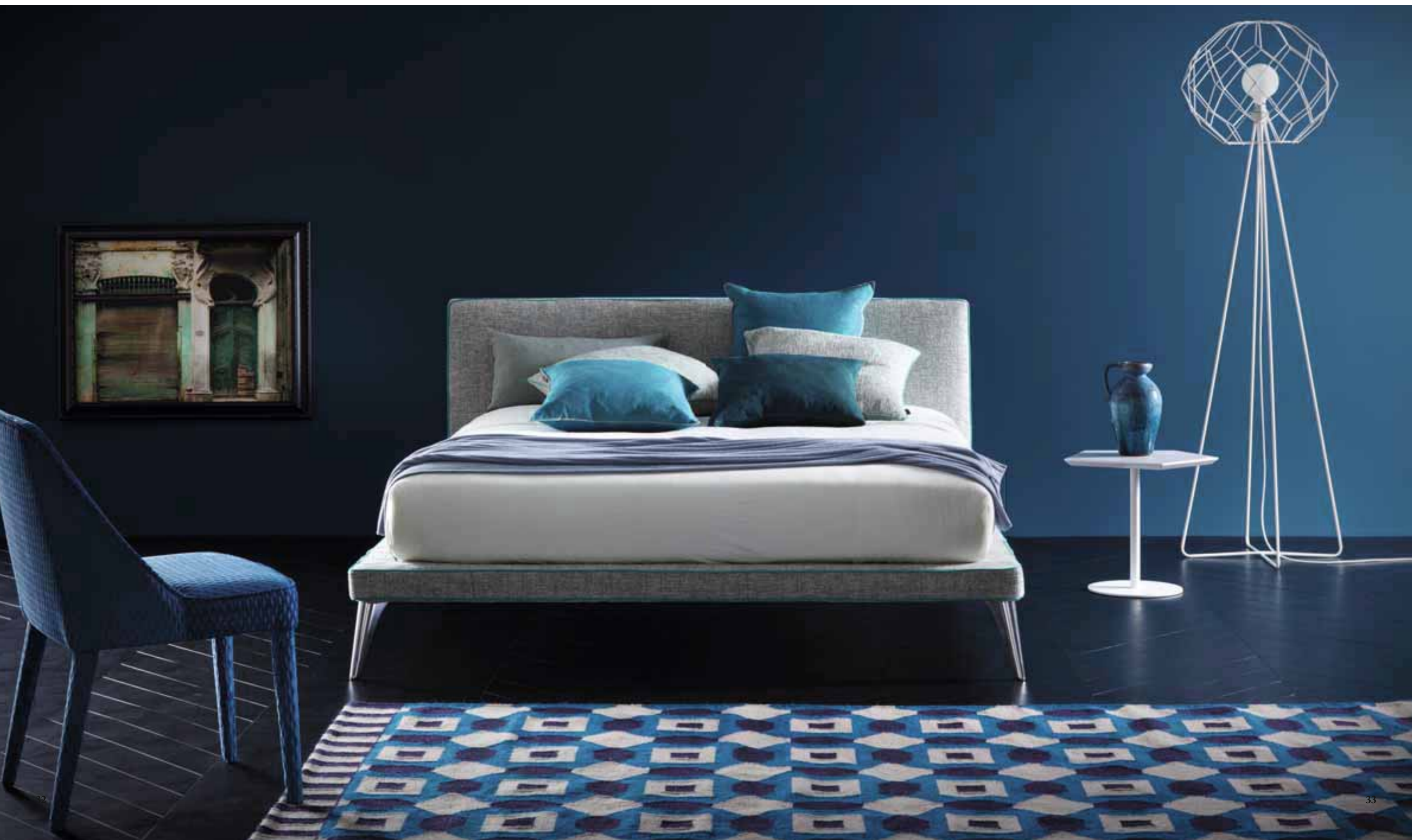

Beat

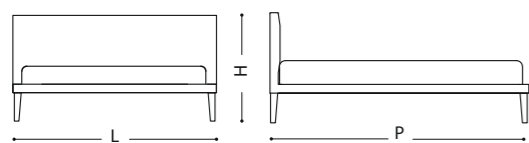

Bed dimensions (cm)
L: 110 · 140 · 160 · 173 · 180 · 190 · 200 · 213
P: 219 · 222
H: 94

Beat: dettagli del ner-
vetto personalizzabile e
del piede.

Beat: details of custo-
mizable piping and Beat
feet.



Aura

SFODERABILE
REMOVABLE LINING

Aura: Letto sfoderabile, in preziosa pelle Nabuk col. 02. Piedini quadro finitura alluminio. Pregiato, morbido, accogliente, è caratterizzato dalla finitura a taglio vivo. **Urban:** pouf sfoderabile, in pelle Dollaro col. 2008, finitura taglio a vivo. **Pop:** comodino con base in acciaio cromato lucido e piano in vetro fumé col. Nero.

Aura: Bed with removable cover made of precious Nabuk leather, colour 02. Aluminium-finished square feet. Valuable, soft, cosy, it is characterized by raw edges. **Urban:** Pouffe with a removable cover in Dollaro leather, colour 2008, and raw edge finish. **Pop:** bedside table with a polished chromium-plated steel base and smoky black glass top.



Aura



Aura: letto sfoderabile, versione con preziosa pelle Nabuk col. 02. Piedini quadro finitura alluminio. Prevista la versione anche in tessuto.

Aura: bed with removable cover made of precious Nabuk leather, colour 02. Aluminium-finished square feet. The fabric version is available as well.

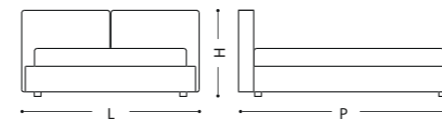

Bed dimensions (cm)
L: 119 · 149 · 169 · 182 · 189 · 199 · 209
P: 229 · 232
H: 93



Dafne

NON SFODERABILE
UNREMOVABLE LINING

Dafne: letto con testata non sfoderabile, rivestito in Tecnonabuk col. 05. Disponibile anche con comodo e pratico vano contenitore e personalizzabile con testata normale o large (come da foto). **Pop:** comodino dal design tondo con struttura in metallo cromato lucido e piano di vetro sagomato e serigrafato. **Dolce Vita:** poltrona rivestita in velluto Luxor col. E038.

Dafne: upholstered bed, covered in Tecnonabuk col. 05. Available with a practical storage unit and customizable with normal or large headboard (as in the photo). **Pop:** Design bedside table Pop with polished chromium-plated metal frame and silk-screen printed moulded glass top. **Dolce Vita:** armchair for bedroom, cover in Luxor fabric col. E038.



Dafne: elegante e prezioso, con una testata imponente (nella foto è visibile nella versione large).

Dafne: elegant and precious, with a stately headboard (in photo you can see the large version).

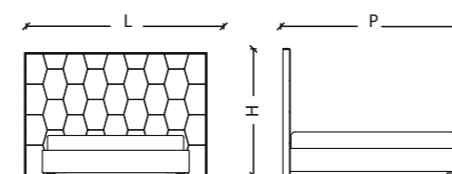

Bed dimensions (cm)
 L: 168 - 215
 P: 216 - 219
 H: 116 - 154

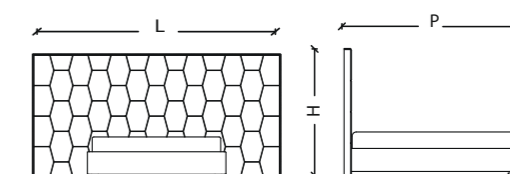

Bed dimensions (cm)
 L: 262 - 310 - 358
 P: 216 - 219
 H: 116 - 154

Cloé

NON SFODERABILE
UNREMOVABLE LINING

Cloé: letto non sfoderabile, in ecopelle col. 09. Piedini quadro finitura alluminio. Un letto classico sempre molto attuale, arricchito da una testiera trapuntata e dal design pulito. È realizzabile con l'applicazione di bottoni Swarovski. Disponibile anche con vano contenitore
Urban: pouff in pelle Extra col. 6011, finitura taglio a vivo.

Cloé: bed upholstered in eco-leather, colour 09 (non-removable upholstery). Aluminium-finished square feet. A classic bed yet always up-to-date, made rich by a quilted headboard and a neat design. It can be decorated with Swarovski buttons. Available also with a storage unit.
Urban: pouffe in Extra leather, colour 6011, and raw edge finish.



Cloé

Lounge: comodino con base in metallo verniciato col. bianco e top in cuoio col. bianco.

Lounge: bedside table with white painted metal base and white leather top.

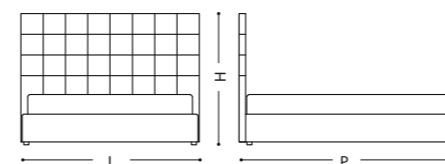

Bed dimensions (cm)
L: 105 · 135 · 155 · 168 · 175 · 185 · 195 · 208
P: 214 · 217
H: 110 · 130

Cloé: disponibile anche con l'applicazione di bottoni Swarovski.

Cloé: available also with Swarovski buttons.

Kyros large

NON SFODERABILE
UNREMOVABLE LINING

Kyros Large: letto in ecopelle Lux col. 122 e cuscini in tessuto Barcellona col. 03. Piedini Ark finitura cromato lucido. Dalla linea molto moderna, qui in versione con comodini integrati nella testata. È proposto anche con accessori come luci di cortesia e coppia cuscini rimovibili e sfoderabili. **Silence:** poltrona con telaio cromato lucido, trapuntata con bottoni in pelle Dollaro col. 2008.

Kyros Large: bed upholstered in eco-leather Lux colour 122 and cushions upholstered in Barcellona fabric, colour 03. Ark feet with polished chromium-plated finish. A bed with a distinctly modern line, here in the version with the bedside units embedded in the headboard. It is also offered with other accessories, e.g. the courtesy lights and a pair of removable cushions with removable cover. **Silence:** armchair with a polished chromium-plated frame, quilted with buttons in Dollaro leather, colour 2008.



Kyros large



Kyros: testata con comodino integrato. Sopra lampada di cortesia mod. Linea e piedino Ark finitura cromato lucido.

Kyros: Headboard with an embedded bedside unit. Above is the courtesy lamp mod. Linea; the Ark feet are in polished chromium-plated finish.

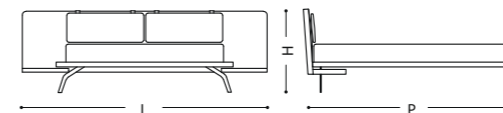

Bed dimensions (cm)
L: 214 · 234 · 247 · 254 · 264 · 274 · 287
P: 219 · 222
H: 81

Kyros

SFODERABILE
REMOVABLE LINING

Kyros: letto sfoderabile in Tecnonabuk col. Bianco e cuscini, removibili e sfoderabili, in tessuto Barcellona col. 03. Piedini Magic finitura alluminio satinato. Cuciture Oceania in contrasto.

Kyros: bed upholstered with removable cover in Tecnonabuk colour white, while the removable cushions have a removable cover made of Barcellona fabric, colour 03. Sandblasted aluminium feet, mod. Magic. Contrasting-colour Oceania-style seams.





Provenza: comodini finitura col. bianco laccato opaco.

Provenza: bedside tables with white mat lacquered finish.

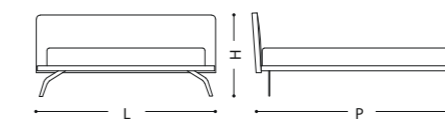

Bed dimensions (cm)
 L: 115 · 145 · 165 · 178 · 185 · 195 · 205 · 218
 P: 219 · 222
 H: 81

“__Kyros is available in two versions”

Ariell

SFODERABILE
REMOVABLE LINING



Ariell: letto sfoderabile, rivestito in Tecnonabuk col.11. Contraddistinto da una testata composta da due alti e morbidi cuscini, anch'essi rivestiti in Tecnonabuk con stampa a pois. Disponibile anche con comodo e pratico vano contenitore. Il tutto è finemente coordinato con la nuova parure di lenzuola Iris. **Colonia:** comodini con frontali rivestiti in Tecnonabuk col.11 a pois.

Ariell: bed with removable cover upholstered in Tecnonabuk col.11. Characterized by a headboard with two soft high cushions, also upholstered in Tecnonabuk with dot print. Also available with a practical storage unit. Everything is finely coordinated with the new Iris sheets. **Colonia:** bedside table with drawer upholstered in Tecnonabuk col.11 with dots.

Ariell

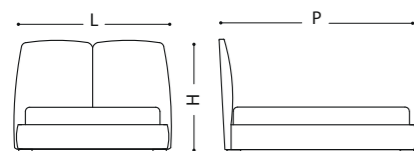

Bed dimensions (cm)
L: 113 · 143 · 163 · 176 · 183 · 193 · 203 · 216
P: 225 · 228
H: 131

Colonia: dettagli dei cassetti rivestiti in Tecnonabukcol.11 a pois.

Colonia: drawers' details upholstered in Tecnonabukcol.11 with dots.





Hermas

NON SFODERABILE
UNREMOVABLE LINING

Hermas: letto in pelle Extra col. 6024. Letto prestigioso dall'imponente testata con bottoni. È disponibile anche con bottoni Swarovski. **Dolce Vita:** poltrona in velluto Luxor col. E046. **Alicia:** comodini con struttura in acciaio lucido e piano in marmo travertino.

Hermas: bed upholstered in Extra leather, colour 6024. An impressive bed with an imposing headboard with buttons; it is available with Swarovski buttons as well. **Dolce Vita:** armchair upholstered in Luxor velvet, col. E046. **Alicia:** bedside table with polished steel frame and travertine marble top

Hermas



Versione con pedane scendiletto e comodini rivestiti in pelle.

In this version, the footboards and the bedside tables are upholstered in leather.

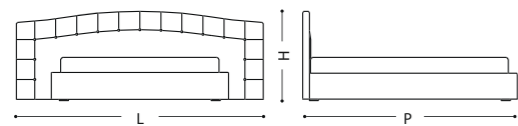

Bed dimensions (cm)
L: 245 · 252 · 262 · 272 · 285
P: 224 · 227
H: 95



Versione senza pedane scendiletto. **Alicia:** comodini con base in acciaio cromato lucido e piano in marmo travertino.

Version without footboard. **Alicia:** Bedside tables with polished chromium-plated steel base and travertine marble top.

“ __Two versions:
two ways to live
the night ”

Melissa

NON SFODERABILE
UNREMOVABLE LINING

Melissa: letto in Ecopelle cat.A col.01, non sfoderabile. Piedino quadro finitura cromo. Testata lavorata a capitonné. Disponibile anche con vano contenitore. **Shar Pei:** poltrona in soffice e confortevole pelliccia ecologica col. Cappuccino. L'applicazione casuale della pelliccia fa di ogni modello, un pezzo d'arredo unico. **Pop:** comodino con base in acciaio cromato lucido e piano in vetro fumé.

Melissa: bed upholstered in eco-leather cat.A, colour 01; the upholstery is not removable. Aluminium-finished square feet. Available also with a storage unit. **Shar Pei:** a soft, comfortable armchair upholstered with walnut eco-fur. The casual positioning of the warm, soft fur makes a unique piece out of every armchair. **Pop:** bedside table with a polished chromium-plated steel base and a smoky black glass top.



Melissa

Melissa: Dall'linea classica ma allo stesso tempo contemporanea, ha una testata lavorata a capitonné da forti e sapienti mani.

Melissa: With a classical, yet contemporary line, its headboard is in Chesterfield style made by strong and skilled hands.

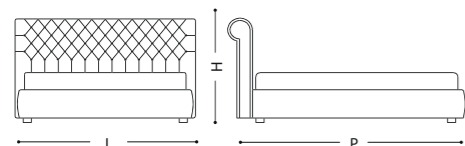

Bed dimensions (cm)
L: 160 · 173 · 180 · 190 · 200
P: 237 · 240
H: 106



Zenas

SFODERABILE
REMOVABLE LINING

Zenas: letto sfoderabile, giroletto in pelle Nabuk col. 17 e testata in pelle Nabuk lux stampa treccia col. 17. Piedini mod. Spillo finitura cromata lucida e coordinato in tinta con motivo rettile. Elegantemente impreziosito dall'utilizzo di pregiato Nabuk stampato a treccia. **Aura:** poltrona interamente rivestita in pelle Nabuk col. 07. **Pop:** comodino con base in acciaio cromato lucido e piano in vetro fumé col. nero.

Zenas: bed with removable cover, bed frame upholstered in Nabuk leather, colour 17, and headboard upholstered in Nabuk lux leather with plait pattern, colour 17. The Spillo feet feature polished chromium-plated finish, while the snake-patterned bedding set is in a matching colour. A touch of precious elegance is conferred by the valuable Nabuk leather printed with a plait pattern. **Aura:** armchair fully upholstered in Nabuk leather, colour 07. **Pop:** bedside table with a polished chromium-plated steel base and a smoky black glass top.



Zenas



Zenas: Elegante e comoda tasca portaoggetti confezionata in pelle Nabuk col.17 da mettere a piacimento sullatestata. **Dakota:** pouff in pelle Nabuk lux stampa treccia col. 17 con piedino Spillo finitura cromato lucido.

Zenas: Elegant and useful large holding pocket made of Nabuk leather, colour 17, to be placed on the headboard at one's will. **Dakota:** Pouffe upholstered in Nabuk lux leather with plait pattern, colour 17, with polished chromium-plated Spillo feet.

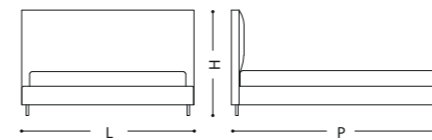

Bed dimensions (cm)
L: 110 · 140 · 160 · 173 · 180 · 190 · 200 · 213
P: 220 · 223
H: 109

Cornelia

SFODERABILE
REMOVABLE LINING



Cornelia: letto sfoderabile, in tessuto Kiev col. 22. Ampia testata e morbido giroletto a balza con spacchi laterali. Il tessuto damascato vintage conferisce un'aria fresca alle forme lineari del letto. Disponibile anche con vano contenitore. **Lounge:** comodini con base in metallo col. brunito e piano rivestito in cuoio col. Testa di moro. **Calypso:** pouff in lino Tropea col. 504 con cuciture pinzate. **Parentesi:** pouff in lino Tropea col. 519.

Cornelia: Bed with removable cover upholstered in Kiev fabric, colour 22. Large headboard and a soft bed frame upholstery with a flounce and side vents. Undoubtedly the vintage damask fabric is the distinctive feature of this bed, and gives a fresh look to its neat lines. Available also with a storage unit. **Lounge:** Bedside tables with a burnished metal base and the top covered with very dark brown leather. **Calypso:** Decorative pouffe upholstered in Tropea linen, colour 504, with welted seams. **Parentesi:** Pouffe upholstered in Tropea linen, colour 519.

Cornelia

Cornelia: Testata imponente ma sottile, rende il letto adatto anche ai piccoli spazi. Particolare del giroletto con balza e nervetto, che definisce tutto il letto.

Cornelia: This imposing yet slender headboard makes the bed suitable even for the narrowest rooms. A detail of the bed frame cover featuring a flounce and piping to better define the whole bed.

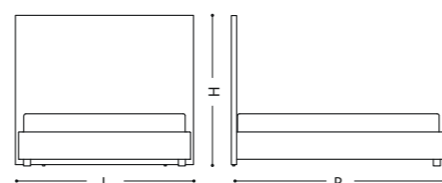

Bed dimensions (cm)
H: 158 · 171 · 178 · 188 · 198 · 211
W: 213 · 216
L: 150

Orfeo

SFODERABILE
REMOVABLE LINING

Orfeo: Letto sfoderabile, in tessuto Dubai col. 17. Piedini Amedeo finitura cromata lucida. Testata con cuscini removibili senza sfoderare il letto grazie a pratiche zip. Il ricamo della testata può essere scelto tra le nostre diverse proposte. Qui con ricamo sartoriale Asia. Disponibile anche con vano contenitore. **Urban:** pouf in pelle Dollaro col. 2008.

Orfeo: Bed with removable cover upholstered in Dubai colour 17. Amedeo feet with polished chromium-plated finish. The headboard cushions can be removed without removing the bed upholstery. The headboard embroidery can be chosen among our various suggestions. This is the Asia-style tailor-like embroidery. Available also with a storage unit. **Urban:** pouffe in Dollaro leather, colour 2008.



Orfeo

Saint Tropez: sdraio in velluto Luxor col E032. Stravagante rivisitazione dello storico sdraio da mare, munito di poggiatesta e braccioli, trapuntato con grandi bottoni, con struttura col. noce.

Saint Tropez: deckchair upholstered in Luxor velvet, colour E032. An extravagant redesign of the historical beach deckchair, fitted with head and arm-rests, quilted with large buttons, and a walnut frame.

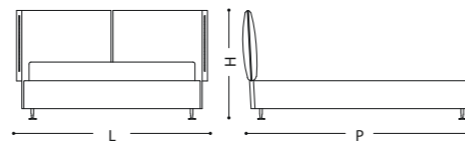

Bed dimensions (cm)
L: 112 · 142 · 162 · 175 · 182 · 192 · 202 · 215
P: 220 · 223
H: 105

Leandro

SFODERABILE
REMOVABLE LINING

Leandro: Letto sfoderabile, in lino Tropea col. 524, cucitura tagliacuci in contrasto col.102 grigio chiaro. La testata a gendarme, il rivestimento in lino con simpatica balza, rendono il letto Leandro informale e adatto ad ogni tipo di arredamento. Disponibile anche con vano contenitore. **Calypso Soft:** pouff in lino Tropea col. 524, con cucitura tagliacuci col. 102 grigio chiaro.

Leandro: Bed with removable upholstery cover in Tropea linen, colour 524, welted seam in contrasting colour no. 102 light grey. The camelback headboard and the linen upholstery with a nice flounce make the Leandro bed an informal piece of furniture, which fits well with any type of furnishing style. Available also with a storage unit. **Calypso Soft:** Pouffe upholstered in Tropea linen, colour 524, with exposed welted seams, colour 102 light grey.

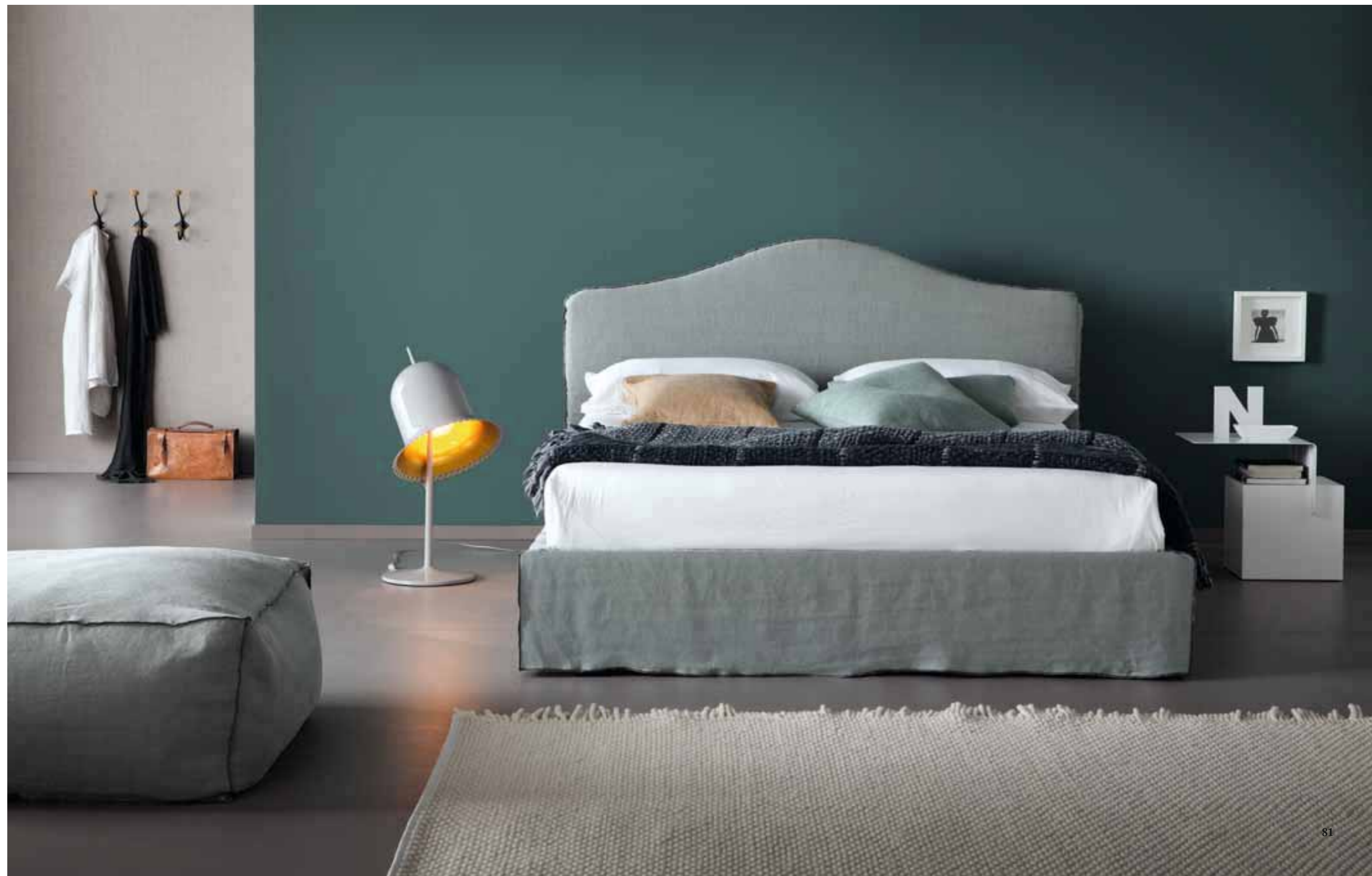

Leandro



Leandro: particolare della cucitura tagliacuci col. 102 grigio chiaro.
Andy: comodino con appoggio in metallo laccato bianco opaco.

Leandro: A detail of the exposed welted seam in colour 102 light grey. **Andy:** Bedside table with mat lacquered white metal top.

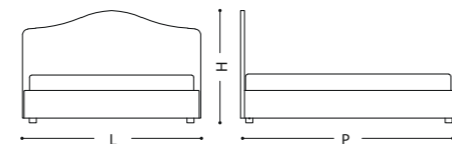

Bed dimensions (cm)
L: 158 · 171 · 178 · 188 · 198 · 211
P: 212 · 215
H: 110



Lucrezia large

SFODERABILE
REMOVABLE LINING

Lucrezia Large: letto sfoderabile, in lino Panarea riga col. 100. Dal sapore mediterraneo con testata over size e cucitura tagliacuci. Disponibile anche con vano contenitore. **Calypso Soft:** pouff sfoderabile, morbido e duttile in lino Tropea col. 524, con cuciture in contrasto a vista.

Lucrezia Large: Bed with removable upholstery cover in linen Panarea Riga, colour 100. A bed with a Mediterranean flavour, an over-size headboard and welted seams. Available also with a storage unit. **Calypso Soft:** Adaptable pouffe with removable soft cover made of Tropea linen, colour 524, with contrasting-colour exposed seams.





Provenza: pratici e multifunzionali comodini finitura col. bianco laccato opaco.

Provenza: Practical multi-function bedside tables in mat lacquered white finish.

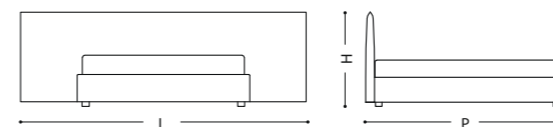

Bed dimensions (cm)
 L: 213 · 243 · 263 · 276 · 283 · 293 · 303 · 316
 P: 218 · 221
 H: 95 · 105

Lucrezia

SFODERABILE
REMOVABLE LINING

Lucrezia: letto sfoderabile, in tessuto Paris col. 05. Le forme essenziali lo rendono adattabile ad ogni diversa esigenza. Delicate cuciture pinzate bordano il letto. Piedini quadro finitura alluminio. Disponibile anche con vano contenitore.

Lucrezia: Bed with removable cover upholstered in Paris fabric, colour 05. Its basic lines make it suitable for any need. Delicate welted seams run all along the bed edge. Aluminium-finished square feet. Available also with a storage unit.



Lucrezia

Lucrezia: particolare della tagliacuci. A lato versione con vano contenitore Pratik con apertura orizzontale. Capiente e comodo per riporre cuscini e coperte, pratico per il rifacimento del letto.

Lucrezia: Detail of the welted seam. Next is the version with the Pratik storage unit with horizontal opening. Spacious and useful to store pillows and blankets, practical when it comes to making the bed.

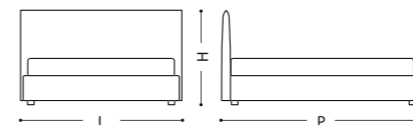

Bed dimensions (cm)
L: 108 · 138 · 158 · 171 · 178 · 188 · 198 · 211
P: 218 · 221
H: 95 · 105



Provenza: panchetta e comodino, deliziosi, pensati in perfetto stile bon ton. La panchetta è disponibile anche con cuscino, qui in velluto Luxor col. E046.

Provenza: the small bench and the bedside table are lovely and perfectly designed to the bon ton style. The small bench can also be fitted with a cushion, here upholstered in Luxor velvet, colour E046.



Parentesi: pouff in tessuto Cortina col. 3 bianco. Da mettere ovunque, disponibile in diversi e divertenti colori.

Parentesi: Pouffe upholstered in white Cortina fabric colour 3. It fits well anywhere and is available in different, amusing colours.

Lucrezia singolo

SFODERABILE
REMOVABLE LINING



Lucrezia: Letto singolo, sfoderabile, in lino Double Face col. principale 6. La particolarità di questo letto è il tessuto reversibile, che permette, solo in questo modello, di rinnovare a piacimento il letto. **Provenza:** comodino finitura col. bianco laccato opaco.

Lucrezia: Single bed with removable upholstery in Double Face linen where the main colour is no. 6.

The special feature of this bed lies in its reversible fabric, which offers the possibility to renovate the bed at one's will, but only with this model.

Provenza: Bedside table with mat lacquered white finish.



Lucrezia: anche il letto Lucrezia singolo puo' essere predisposto per il vano contenitore con apertura orizzontale Pratik, un ottimo vano interno dove riporre coperte, cuscini e il cambio stagionale.

Lucrezia: Also the single bed Lucrezia can be equipped with a storage unit with the Pratik horizontal opening; it is an excellent internal container for blankets, cushions and clothes.



Sommier

SFODERABILE
REMOVABLE LINING

Sommier: sommier sfoderabile rivestito in tessuto Italy col.02 , personalizzabile con vari tipi di cuciture e finiture. Pratico, diventa un vero letto se abbinato alla testata **Misura**, personalizzabile al centimetro. Questo modello è proposto sia nella versione Above, con materasso a filo giroletto (come da foto), sia con materasso incassato. Disponibile anche con comodo e pratico vano contenitore. **Grace:** comodino stonato con cassetto, struttura in legno massello e multistrato colore Marrone-grigio. **Mango:** tavolini/pouf rivestiti in tessuto Coimbra col. 01 e 03. Top disponibile in diverse finiture. **Epoque:** lampade a sospensione dalla forma cilindrica, rivestite con tessuti Chaarme.

Sommier: sommier with removable cover upholstered in fabric Italy col. 02 , customizable with different types of finishes. Practical and easy, it becomes a real bed thanks to the headboard **Misura**, which can be customize both in width and length. This bed is presents in two versions: Above, with wire mattress bed frame (as in the photo) or with embedded mattress. Available with a practical storage unit. **Grace:** bedside table with a single drawer, made with solid and multilayered wood frame with solid slides colour Brown-grey. **Mango:** bedside table/pouf upholstered in fabric Coimbra col. 01 and 03. Top available with differents finishes. **Epoque:** pendant lamps with a cylindrical shape, upholstered with Chaarme's fabrics.



———— L ————

———— P ————

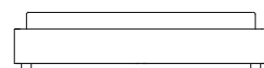
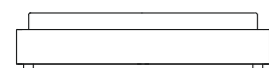

Bed dimensions (cm)
L: 92 · 102 · 132 · 152 · 165 · 172 · 182 · 192 · 205
P: 211 · 214
H: 31

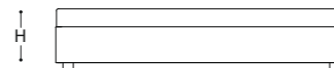
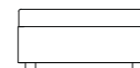

Bed dimensions (cm)
L: 110 · 140 · 160 · 173 · 180 · 190 · 200 · 213
P: 219 · 222
H: 28

Calliope

SFODERABILE
REMOVABLE LINING

Calliope: divano sfoderabile, in tessuto Cortina col. 02. Divano o letto singolo, semplice e trasformabile in un eclettico doppio singolo o in un reinventato letto matrimoniale. Fianchi e schienali personalizzabili a seconda delle più varie esigenze. Possibilità di cassetto contenitore.

Calliope: sofa with removable upholstery in Corina fabric, colour 02. Either a sofa or a single, it can be easily converted into two eclectic single beds, or into a reinvented double bed. The sides and the back can be customized according to the customer's requirements. Available with a chest unit.



Calliope

Calliope: versione con secondo letto singolo preparato e coordinati in abbinamento.

Calliope: In this version, the second bed is ready for use with a matching bedding set.

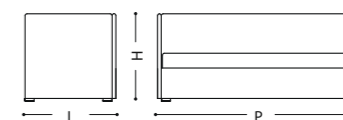

Bed dimensions (cm)
L: 92
P: 212
H: 90

Calliope



Calliope: Il meccanismo di apertura semplice e fluido permette di trasformare il divano in due comodi lettini singoli, sistemabili anche senza essere disfatti, pronti per l'arrivo di un nuovo ospite inatteso.

Calliope: The simple and smooth opening mechanism can turn this sofa into two comfortable single beds, which can be stored even with the bedding to be ready to welcome one more unexpected guest.

Urania

SFODERABILE
REMOVABLE LINING

Urania: divano letto in tessuto Cortina col. 21 con nervetto in fettuccia di cotone col.123 nero, trasformabile, con braccioli, rete elettrosaldata e materasso. Dalle linee sobrie è munito di soffici schienali in piuma ed accoglienti sedute in poliuretano espanso. Facilmente trasformabile, con semplici gesti diventa un comodo e confortevole letto.

Urania: sofa bed in Cortina fabric col. 21 with cotton piping col. 123 black. With armrests, welded steel mesh and mattress. A sofa bed with unpretentious lines, its soft backrest are stuffed with down and the inviting seat cushions are in polyurethane foam. Easily to convert with a few simple movements, it becomes a comfortable bed.



Bed dimensions (cm)
H: 89
P1: 98
P2: 210
L1: 120
L2: 190 - 210

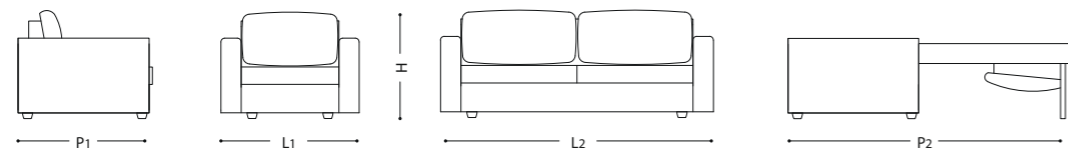

Bed dimensions (cm)
H: 89
P3: 160
L3: 107
L4: 175 - 195

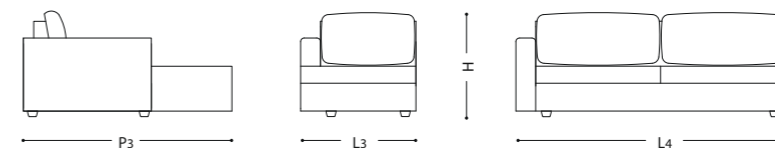

Urania

SFODERABILE
REMOVABLE LINING



Urania dimensions (cm)
H: 89
P1: 98
P2: 210
L1: 120
L2: 190 · 210

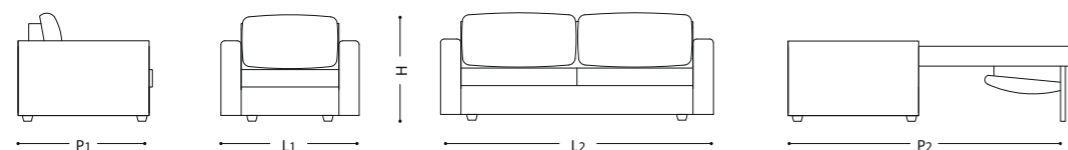

Urania dimensions (cm)
H: 89
P3: 160
L3: 107
L4: 175 · 195

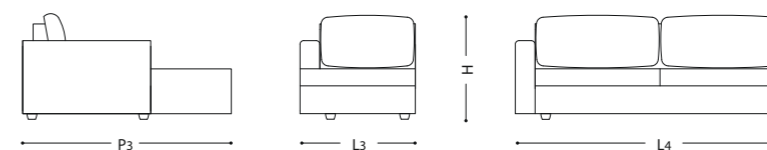



Sebastian

SFODERABILE
REMOVABLE LINING

Sebastian: letto sfoderabile, cuscini e giroletto in tessuto Barcellona col. 3. Retro testiera, cordino e fibbie abilmente confezionati in cuoio col. naturale. Dal desiderio di contaminare e mescolare mode e materiali, nasce il letto Sebastian, accattivante e sofisticato nelle finiture, è l'esempio di quanto il dettaglio non sia mai una banalità.

Sebastian: Bed with removable cover, cushions and bed frame upholstered in Barcellona fabric, colour 3. The headboard back, the cord and the buckles are all skilfully made in natural-colour leather. The wish to mix and match trends and materials has generated the bed Sebastian. The charm and elegance of its finishes underline the fact that details are never unimportant.

Sebastian



Morbidi cuscini, completamente e facilmente sfoderabili, custoditi da una struttura sapientemente e delicatamente lavorata a mano in cuoio col. naturale.

These soft cushions are wrapped in a skilfully and delicately hand-worked case made of natural-colour leather and which can be removed fully and easily.

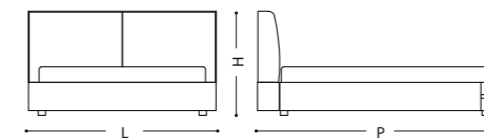

Bed dimensions (cm)
L: 162 · 175 · 182 · 192 · 202 · 215
P: 235 · 238
H: 102

Sebastian



Servetto e specchiera in cuoio col. naturale. La specchiera è proposta anche senza fibbie.

The rack and the large mirror are in natural leather. The mirror comes also without buckles.

“__Sebastian:
so sophisticated
finishes”



Ariston

NON SFODERABILE
UNREMOVABLE LINING

Ariston: letto dalla forma inusuale e geometrica, è qui proposto in pelle Dollaro col. 2001. Versatile anche nell'allestimento, è disponibile con il materasso tradizionale o rotondo. Nella foto, con testata alta e trapuntata.

Ariston: a bed with an unusual geometric shape, it is here proposed with Dollaro leather colour 2001. Also its fitting are versatile; it comes with the traditional mattress or with a round mattress. In this picture, it has a high and quilted headboard.

Ariston

Ariston: proposto con testata liscia e bassa. Servetto in cuoio col. Testa di moro, facile da spostare e adattabile a mille usi con un piano di appoggio semplice e pratico. Specchiera rivestita in pelle Dollaro, col. 2001. Dalla linea semplice è adatta sia alla zona notte che living.



Ariston: version with a plain, low headboard. The very dark brown leather rack can be easily moved and adapts to endless uses, thanks to its simple and practical rest top. Large mirror with a frame in Dollaro leather colour 2001. Its simple line fits well in the night-time area and in the living as well.

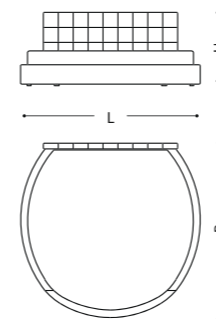

Bed dimensions (cm)
L: 258
P: 250
H: 69 · 106

Servetto in cuoio col. testa di moro, facile da spostare e adattabile a mille usi con un piano di appoggio semplice e pratico.

This very dark brown leather rack can be easily moved and adapts to endless uses, thanks to its simple and practical rest top.



Vanilla: Toilette proposta laccata col. bianco lucido, è fornita di un comodo vano portaoggetti sagomato e rivestito, di due cassettini con interno rivestito in microfibra, e da un pratico specchio. Specchiera rivestita in pelle Dollaro col. 2001. **Cacao:** pouf in pelle Dollaro col. 2003.

Vanilla: This dressing table is here pictured in the glossy lacquered white version, fitted with a useful holding compartment that is moulded and lined, with two microfiber-lined drawers, and a useful mirror. Large mirror with a frame in Dollaro leather, colour 2001. **Cacao:** pouffe in Dollaro leather, colour 2003.

“ __ Vanilla:
to give a magic
touch ”



Tereo

SFODERABILE
REMOVABLE LINING

Tereo: letto sfoderabile, in velluto Luxor col. E044 con nervetto in cotone col. 102 grigio chiaro. Dalla forma classica impreziosita da una testata dal nobile aspetto. Il rivestimento del giroletto scende a gonna.

Tereo: bed with removable upholstery in Luxor velvet, colour E044, with piping in cotton col. 102 light grey. A classic style made more precious by a noble-looking headboard. The bed frame upholstery comes down as a gown.

Tereo



Tereo: Particolare della testata dalla forma classica e con nervetto decorativo.

Tereo: Detail of the headboard with a classical shape and a decorative piping.

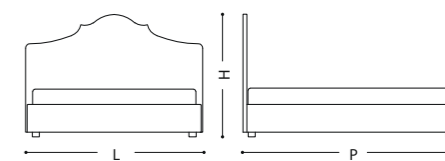

Bed dimensions (cm)
L: 158 · 171 · 178 · 188 · 198 · 211
P: 212 · 215
H: 122





Leandro

SFODERABILE
REMOVABLE LINING

Leandro: letto sfoderabile, in tessuto Damasco col. 06. Il ricco tessuto operato con disegni floreali ad effetto lucido e opaco, la testata a gendarme, il coordinato in raso regalano al letto un gusto classico. **Dolce Vita:** poltrona e pouf in velluto Luxor col. E046.

Leandro: bed with removable cover upholstered in Damasco fabric, colour 06. The precious wrought fabric features a flowery pattern with a glossy and matt effects which, when added to the camelback headboard and to the satin bedding set, confer a classical look to the bed. **Dolce Vita:** armchair and pouffe upholstered in Luxor velvet, colour E046.

Leandro

Leandro: letto con coordinato in raso con cuscini e coperta lavorati a treccia in calda lana.

Leandro: Bed with satin bedding set, with warm wollen cushions and blanket with a plait pattern.

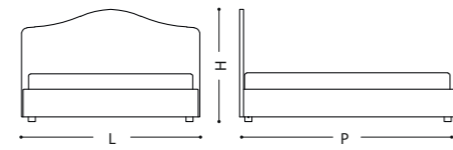

Bed dimensions (cm)
L: 158 · 171 · 178 · 198 · 211
P: 212 · 215
H: 110



Grace: Comodino, finitura laccato lucido col. Corda con elegante maniglia art. 104, realizzata a mano e composta da un ciordolo laccato cromo e pendente a tema col. latte. Sotto proposto con maniglia art. 678.

Grace: Bedside table with polished lacquered ecru finish and an elegant handle, code 104. The handle is handmade and it features a chromium-plated charm and a milk-white matching pendant. In the photo below it is shown with handle code 678.





Dolce Vita

POLTRONA CON POUFF
ARMCHAIR AND POUFFE

Dolce Vita: comoda poltrona e pouf in velluto Luxor col. E046, dalle armoniose linee e con cuciture Europa sartoriali e ricamate.

Dolce Vita: comfortable armchair and pouffe upholstered in Luxor velvet, colour E046, with harmonious lines and embroidered tailor-like Europa-style seams.



Altea

NON SFODERABILE
UNREMOVABLE LINING

Altea: testata in tessuto Plaza col. 562, giroletto sfoderabile e laterali della testata in velluto Luxor col. E003. Dall'interpretazione in chiave contemporanea ed innovativa di forme che vengono dal passato, nasce il letto Altea. Il gusto classico ed italiano, è stato trasformato, anche grazie all'utilizzo di frange ornamentali in cotone, in un letto glamour e di tendenza. **Dolce Vita:** panca in velluto Luxor col. E046.

Altea: headboard upholstered with Plaza fabric, colour 562; the bed frame upholstery is removable and the sides of the headboard are upholstered in Luxor velvet, colour E003. The Altea bed is the result of the contemporary and innovative interpretation of shapes that remind of the past. The classical Italian style has evolved also with the insertion of decorative cotton fringes to generate a trendy, glamorous bed. **Dolce Vita:** bench upholstered in Luxor velvet, colour E046.

Altea



Altea: Dalla forma avvolgente e artigianalmente lavorata a mano, è disponibile anche nella versione senza bottoni e con Swarovski.

Altea: With an enveloping shape, this hand-made item is available also without buttons and with Swarovski crystals.

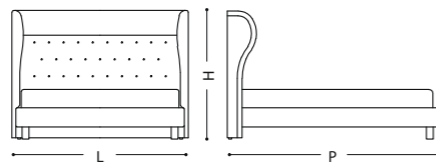

Bed dimensions (cm)
L: 160 · 173 · 180 · 200 · 213
P: 215 · 218
H: 130



Altea: divanetto 2 posti in velluto Luxor col. E003, e frange in cotone. Sinuoso, elegante e comodo, adatto ad un momento di caldo relax.

Altea: 2-seat sofa upholstered with Luxor velvet, colour E003, and cotton fringes. Winding, elegant and comfortable, the right place for a moment of warm relaxation.



Zuma

NON SFODERABILE
UNREMOVABLE LINING

Zuma: letto rivestito in velluto Paraiso col. 1008. Dalla linea importante e ricca, grazie alla lavorazione capitonné, completamente realizzata a mano. Il giroletto è disponibile anche nella versione liscia. È possibile aggiungere un apposito vano contenitore. **Panca Zuma:** elegante, rivestita in velluto Paraiso col. 1008, con lavorazione capitonné. **Cruz:** tavolini con struttura in metallo e ripiano in marmo Imperador.

Zuma: upholstered bed cover in Paraiso velvet col. 1008. Bed with a prestigious and important design, thanks to the handmade capitonné. The bed frame can be chosen also in the smooth version. Available with a practical storage unit. **Zuma bench:** upholstered bench with capitonné, cover in Paraiso velvet col. 1008. **Cruz:** bedside table with metallic structure and table top in Imperador marble.

Zuma



Zuma: letto dallo stile unico che diventa il protagonista della stanza da letto; perfetto se si vuole coniugare lo stile moderno con un tocco di classe. **Jane:** semplice e lineare seduta con struttura in legno di faggio, rivestita in velluto Paraiso col. 1008 e nervetto in cotone col. 117 blu notte. Perfetta sia per la zona giorno che quella notte.

Zuma: a unique and stylish bed which become the star of your bedroom; perfect if you want to mix different style with a classy touch. **Jane:** simple and linear armchair with bench wood structure. Upholster in Paraiso velvet col. 1008 and cotton piping col. 117 night blue. Jane is perfect even for living room and bedroom.

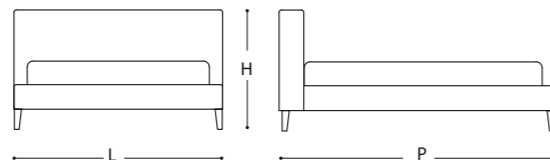

Bed dimensions (cm)
L: 138 · 158 · 171 · 178 · 188 · 198 · 211
P: 232 · 235
H: 103



Olimpia

NON SFODERABILE
UB REMOVABLE LINING

Olimpia: letto non sfoderabile, con testata in Tecnonabuk col. 11 treccia e giroletto liscio. La testata è composta da diversi pannelli affiancati e sagomati, ed è disponibile anche nella versione large con pannelli laterali, con o senza la cornice in acciaio lucido. Piedini quadro con finitura alluminio. Disponibile anche con vano contenitore. **Casablanca:** comodini e comò rivestiti in Tecnonabuk col. 11 treccia e struttura liscia.

Olimpia: fabric bed with non-removable upholstery; the headboard is upholstered in Tecnonabuk colour 11 braid and smooth bedframe. The headboard is made of several shaped panels placed one close to the other, with or without a polished steel frame. Aluminium-finished square feet. Available also with a storage unit. **Casablanca:** bedside table and pouffe upholstered in Tecnonabuk colour 11 braid on the front and smooth structure.

Olimpia



Flower: poltroncina rivestita in Tecnonabuk col. 11 treccia.

Flower: armchair realized in Tecnonabuk leather col. 11 braid.



Casblanca: comodino con struttura in Tecnonabuk col. 11e frontali cassetto in Tecnonabuk col. 11 treccia.

Casablanca: bedside table with structure in Tecnonabuk leather col. 11 and fronts in Tecnonabuk col. 11 braid.



Olimpia large: testata ampliata aggiungendo dei pannelli laterali in tessuto Couture col. 7704. **Alicia:** comodino con base in acciaio cromato lucido e piano in marmo col. nero assoluto.

Olimpia large: this headboard was made larger by adding some side panels upholstered with Couture fabric, colour 7704. **Alicia:** Bedside table with a polished chromium-plated steel base and an absolute-black marble top.

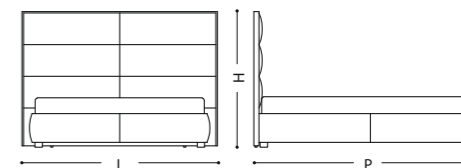

Bed dimensions (cm)
L: 176 · 183 · 193 · 203 · 216
P: 214 · 217
H: 128

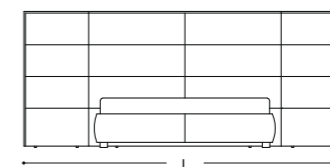

Bed dimensions (cm)
L: 296 · 303 · 313 · 323 · 336
P: 214 · 217
H: 128

“ __Another version of Olimpia: wide format ”

“ — II — Chærme
complements and
technical informations ”



“ __ Chaarme’s groups. ”



Colonia



Loto



Casablanca



Vanilla



Grace



Mango

Cruz

Corallo

Vela

TAVOLINI E POUF / BEDSIDE TABLES AND POUFFES

Chaarme propone una serie di nuovi tavolini e pouf, dalle forme e dai materiali diversi, che permettono di creare differenti combinazioni e personalizzazioni. Potrete divertirvi a mixare l'acciaio con il legno naturale o col marmo oppure il cuoio.

Chaarme presents a new bedside table serie, by the differents shake and materials, which allow to create differents combinations and customizations. You can mix steel with natural wood or marble or leather.

“ Chaarme’s
bedside tables. ”



Lady

Jane

Ava

Jane

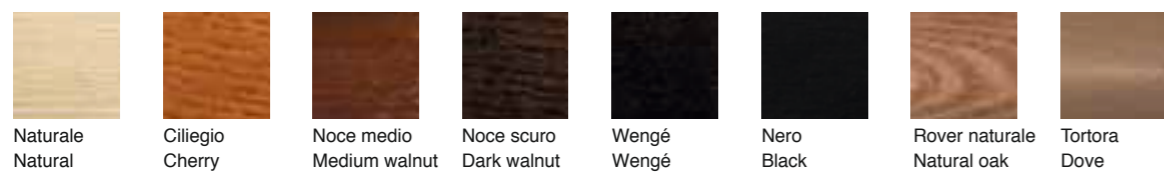

SEDIE E POLTRONE / CHAIRS AND ARMCHAIRS

Sedie e sedute dalla linea contemporanea, sobria e moderna, personalizzabili con tutti i tessuti Chaarme, per l'arredo della zona notte e living.

Chairs and armchairs with a contemporary, linear and modern design. All models are customizable and can be covered with all our textiles, to furnish the living room and the bedroom.

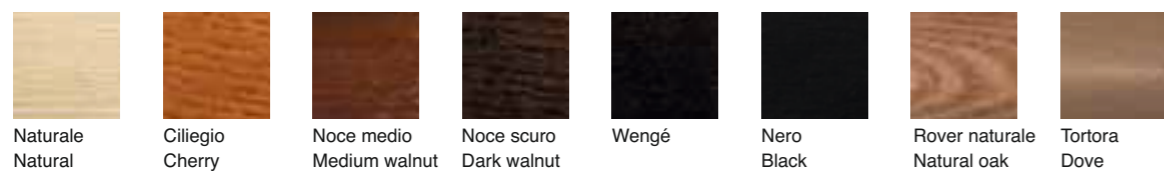

POLTRONE / ARMCHAIRS

Sedute dalla linea classica, rivisitate in chiave contemporanea e completamente personalizzabili con le finiture Chaarme.

Armchairs by the classical design, re-thinking in a contemporary way and completely customizable with Chaarme's finishes.



TAVOLINI, COMODINI, POLTRONE E POUF
BEDSIDE TABLES, ARMCHAIRS AND POUFFES

“ — Seats and
bedside tables. ”



TAVOLINI, COMODINI, POLTRONE E POUF
BEDSIDE TABLES, ARMCHAIRS AND POUFFES

“__ Chaarme’s
complements.”



Aura

Aura

Flower

Aura

TAVOLINI, COMODINI, POLTRONE E POUF
BEDSIDE TABLES, ARMCHAIRS AND POUFFES

“__ Chaarme’s
armchairs.”

Misaki

Chaarme arricchisce la linea di complementi con il nuovo separé, Misaki. Dal fascino senza tempo, dona un tocco di eleganza ad ogni spazio. Proposto in due dimensioni, ha una struttura in legno disponibile in tre finiture e personalizzabile sia grazie all'ampia gamma di tessuti, cuoio e pelli sia a diversi optional applicabili.

Chaarme's complements collection has been enriched by the new separé, Misaki. Accessory with a timeless charme, giving a touch of regal elegance to any room. It's presents in two dimensions, it has a wood structure available in three finishes and customizable with a wide range of fabrics and leathers even with many optional, which you can apply on it.





FINITURE STRUTTURE PER SEPARÉ MISAKI
FINISHES STRUCTURES FOR MISAKI SEPARÉ



Bianco
White



Grigio Avio
Air-force Blue



Wengé
Wengé



La collezione di lampade è stata ampliata e arricchita da pezzi unici, di varie forme e dimensioni e in perfetta armonia col resto dei letti Chaarme. Una linea moderna, con un design esclusivo e di sicuro effetto per rendere originale la casa. I nostri esperti saranno a vostra disposizione per una consulenza sulla scelta dei modelli e delle finiture.

Chaarme's new collection includes also new lamps, with different shapes and dimensions, in harmony with all our beds. A modern line with a unique design to enrich your house. Our experts will help you about the choice of the right models and finishes.



TESSUTI PER LAMPADE E TAVOLINI /
FABRICS FOR LAMPS AND BEDSIDE TABLE

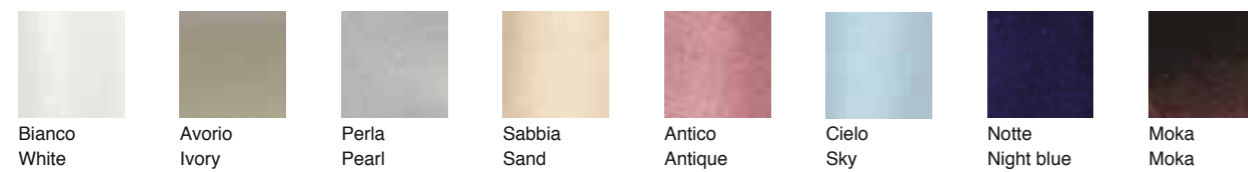

FINITURE STRUTTURE PER LAMPADE E TAVOLINI /
FINISHES STRUCTURES FOR LAMPS AND BEDSIDE TABLE

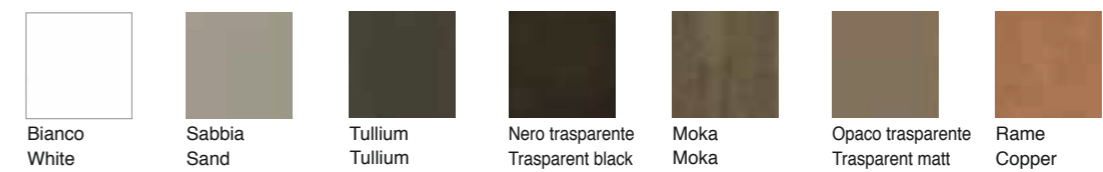



“ — Carpets selection.”

DOUBLEFACE FLORENCE



DOUBLEFACE LINE



ZANTE



CORINTO

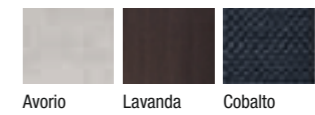

NAIROBI



NAIROBI BICOLOR

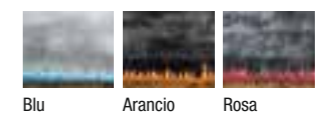

“ Handles selection.”



104
Acciaio e Cuoio Intrecciato
Bianco Panna
Finitura / Finish: Lucido



110 Satinato
Ottone
Finiture / Finishes: Lucido -
Satinato - Palladiato



110 Lux Oro
Ottone con Swarovski
Finiture / Finishes: Lucido -
Satinato - Palladiato



678 Lucido
Cristallo trasparente- Base cilindrica
Finitura / Finish:
cromo lucido / polished chrome



678 Placcato
Cristallo trasparente- Base cilindrica
Finitura / Finish:
cromo lucido / polished chrome



130 Lucido
Ottone
Finiture / Finishes: Lucido -
Satinato - Palladiato



130 Palladiato
Ottone
Finiture / Finishes: Lucido -
Satinato - Palladiato



130 Lux Lucido
Ottone con Swarovski
Finiture / Finishes: Lucido -
Satinato - Palladiato



140 Palladiato
Ottone
Finiture / Finishes: Lucido -
Satinato - Palladiato



130 Lucido
Ottone
Finiture / Finishes: Lucido -
Satinato - Palladiato



150 Lucido
Ottone
Finiture / Finishes: Lucido -
Satinato - Palladiato



150 Palladiato
Ottone
Finiture / Finishes: Lucido -
Satinato - Palladiato



160 Anticato
Acciaio
Finiture / Finishes: Lucido -
Anticato



165
Acciaio
Finiture / Finishes: Satinato



400 Oro Lucido - Ecopelle
Acciaio e Rivestimento*
Finiture / Finishes:
Cromo Lucido - Oro Lucido



400 Cromo lucido - Stampa rettile
Acciaio e Rivestimento*
Finiture / Finishes:
Cromo Lucido - Oro Lucido



500 Stampa Rettile
Acciaio e Rivestimento*
Finitura / Finish: Lucido



500 Ecopelle
Acciaio e Rivestimento*
Finitura / Finish: Lucido



600 Lucido
Acciaio
Finiture / Finishes: Lucido -
Satinato



600 Satinato
Acciaio
Finiture / Finishes: Lucido -
Satinato

* Realizzato con la stessa finitura dell'articolo a cui la maniglia è abbinata



“__ Laccati Lacquered.”

Legno laccato / Lacquered wood



Legno / Wood



Legno Naturale Invecchiato

Vetro / Glass



Nero Tortora Corda

Marmo / Marble



Imperador Nero Assoluto Travertino Carrara

Vero cuoio e rigenerato / real and regenerated leather



Nero Grigio Antracite Testa di Moro
Naturale Toscano Sabbia Bianco

Pelle ecologica / Eco-leather

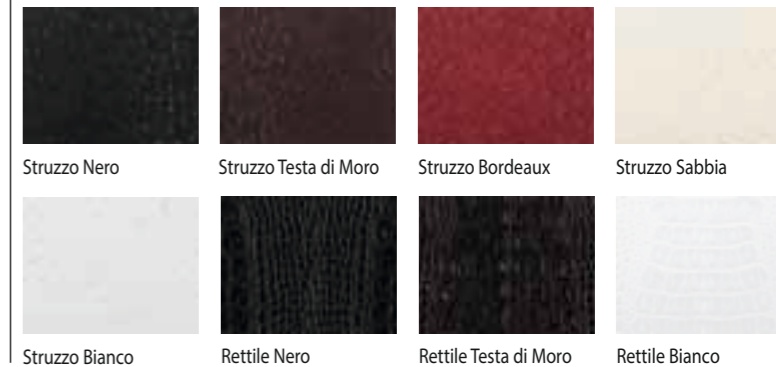

Struzzo Nero Struzzo Testa di Moro Struzzo Bordeaux Struzzo Sabbia
Struzzo Bianco Rettile Nero Rettile Testa di Moro Rettile Bianco

Pellicce / furs



Nero Testa di Moro Noce Perla Bianco

“ — Colored stitching. ”

I dettagli sono importanti; testimoniano la nostra attenzione maniacale per la qualità. Desideriamo rendervi partecipi di questa nostra passione permettendovi di personalizzare il vostro letto, i cuscini e i complementi scegliendo il colore delle cuciture....

Details are important, they prove our never-fading attention for quality. We would like you to participate in our passion for details by giving you a chance to customize bed, cushions and complements by choosing the stitching colours...

Colori disponibili per finiture nervetto in cotone e cuciture tagliacuci Available colours for cotton piping and visible stitching stapled

					
Bianco 100	Grigio chiaro 102	Corda 101	Giallo 105	Beige 103	Rosa 104
					
Tortora 106	Arancio 107	Rosso Vivo 108	Rosso Bordeaux 109	Fucsia 110	Viola 111
					
Prugna 112	Celeste 113	Azzurro 114	Verde Petrolio 115	Avio 116	Blu Notte 117
					
Verde Oliva 118	Verde Militare 119	Verde Pavone 120	Verde Bosco 121	Marrone 122	Nero 123



“ — Your custom mattress. ”

Trascorri un terzo della tua vita a letto e il materasso è responsabile di un buon riposo, o di un cattivo sonno, con tutto ciò che ne consegue. Per questo si può affermare che il materasso è un elemento estremamente importante per la nostra salute e deve giovare al benessere del corpo e dello spirito. Per poterci indirizzare verso la scelta di un materasso ottimale che risulti adeguato alle nostre esigenze è necessario conoscere bene le caratteristiche di ciascuna tipologia, ma è altrettanto indispensabile avere bene in mente l'obiettivo che si vuole raggiungere, così da compiere una scelta mirata. Abbiamo creato il sistema Box Spring Vip che puoi abbinare a tutti i nostri letti, inserendo un materasso a molle indipendenti con una base di supporto in multistrato fessato all'interno del giroletto (vedi pag. 183) per farti sì che il tuo materasso possa appoggiarsi su un piano omogeneo e sfruttare al massimo le sue caratteristiche tecniche.

We spend a third of our lives in bed and the mattress is responsible for a good or a bad sleep with all the consequences. For that reason, the mattress is extremely important for our health, physically and mentally. Choose the best mattress for our necessities means to know each typology, but it's extremely important to reach the best compromise between desires and real possibilities. We have created Box Spring Vip System, which you can match with all our beds by inserting a mattress with pocket springs and a multilayered support base inside the bed frame (see page 183). In this case, your mattress will be supported on a solid plan and you can take all the advantages by its potential.



GIZA

- 1 Fodere a scelta (SILVER CLIMA ALOE, ANALLERGICO, EASY)
Linings to choose (SILVER CLIMA ALOE, ANALLERGICO, EASY)
- 2 Latice naturale
Natural latex
7 zone a portata differenziata
7 zones with different flow rate.



STRUTTURA Frame

Latice naturale
Natural latex

ALTEZZA
Height 21 cm

FODERA SFODERABILE
Removable cover SILVER CLIMA ALOE, ANALLERGICO, EASY

MANUTENZIONE FODERA
Cover care SILVER CLIMA ALOE, ANALLERGICO, EASY

MISURE SPECIALI
Custom dimensions ✓

EFESO

- 1 Fodere a scelta (FISSO, SILVER CLIMA ALOE, ANALLERGICO, EASY)
Linings to choose (FISSO, SILVER CLIMA ALOE, ANALLERGICO, EASY)
- 2 Lato in memory foam di grosso spessore (5cm c.a.)
Side thick of memory foam (5 cm)
- 3 Lato in resina elastica bugnata a zone di portata differenziata
Elastic resin side, rusticated in differential capacity areas
- 4 Carenatura perimetrale antiaffossamento
Perimetral embossment against sinking
- 5 Molle insacchettate indipendenti
Independent pocketed springs



STRUTTURA Frame

800 molle insacchettate indipendenti a 7 zone di portata differenziata
800 independent pocketed springs in 7 differential capacity areas

ALTEZZA
Height 24 cm

FODERA SFODERABILE
Removable cover SILVER CLIMA ALOE, ANALLERGICO, EASY

MANUTENZIONE FODERA
Cover care FISSO SILVER CLIMA ALOE, ANALLERGICO, EASY

MISURE SPECIALI
Custom dimensions ✓

EGITTO

- 1 Fodere a scelta (SILVER CLIMA ALOE, ANALLERGICO, EASY)
Linings to choose (SILVER CLIMA ALOE, ANALLERGICO, EASY)
- 2 Strato in memory foam termoresponsibile e automodificante
Thermoresponsive and self-shaping memory foam side
- 3 Resina elastica microforata di sostegno ad alta densità
High support density elastic resin microperforated

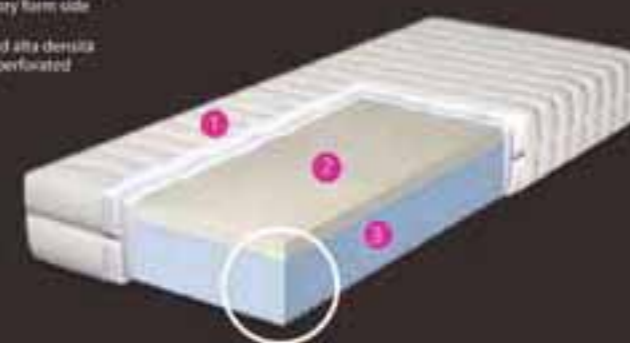

STRUTTURA Frame

materasso in schiuma viscoelastica che garantisce una distribuzione uniforme altamente traspirante, evita la formazione di muffe e batteri
viscoelastic foam mattress which ensure an even distribution high transpiring, avoid any formation of mould and mites

ALTEZZA
Height 30 cm

FODERA SFODERABILE
Removable cover SILVER CLIMA ALOE, ANALLERGICO, EASY

MANUTENZIONE FODERA
Cover care SILVER CLIMA ALOE, ANALLERGICO, EASY

MISURE SPECIALI
Custom dimensions ✓

CORFU'

- 1 Fodere a scelta (SILVER CLIMA ALOE, ANALLERGICO, EASY)
Linings to choose (SILVER CLIMA ALOE, ANALLERGICO, EASY)
- 2 Lato in memory foam bugnato
Side made in rusticated memory foam
- 3 Materasso in resina elastica di sostegno ad alta intensità con sagomatura anatomica
Elastic resin mattress with high intensity support and anatomical shape

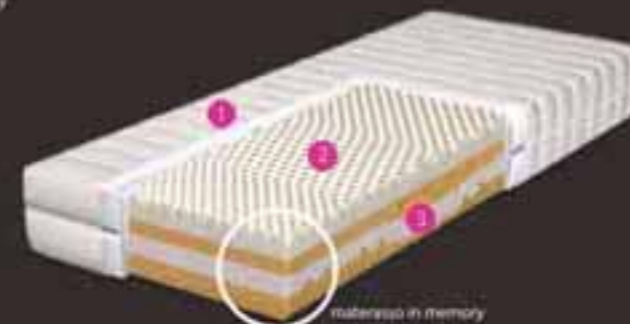

STRUTTURA Frame

materasso in memory
memory mattress

ALTEZZA
Height 24 cm

FODERA SFODERABILE
Removable cover SILVER CLIMA ALOE, ANALLERGICO, EASY

MANUTENZIONE FODERA
Cover care SILVER CLIMA ALOE, ANALLERGICO, EASY

MISURE SPECIALI
Custom dimensions ✓

RODI

- 1 Fodere con trattamento ACTIGARD
Linings with ACTIGARD system
- 2 Imbottitura fibra misto lana/cotone
Upholstery in poly wool/cotton fibre
- 3 FISIO-TECH, box system antiaffossamento
FISIO-TECH, box system t against sinking
- 4 Carenatura perimetrale antiaffossamento
Perimetral enforcement against sinking
- 5 Molle biconiche Bonnel
Bonnel bioconical springs

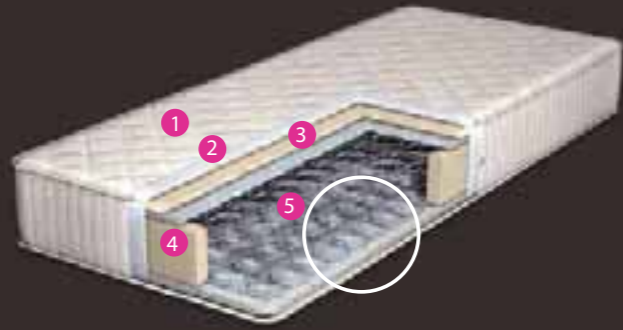

STRUTTURA
Frame

materasso a 300 molle biconiche Bonnel
mattress with 300 Bonnel bioconical springs

ALTEZZA
Height 22 cm

FODERA SFODERABILE
Removable cover -

MANUTENZIONE FODERA
Cover care FISSO

MISURE SPECIALI
Custom dimensions ✓

ARTEMIDE

- 1 Fodere a scelta (FISSO, SILVER CLIMA ALOE, ANALLERGICO, EASY)
Linings to choose (FISSO, SILVER CLIMA ALOE, ANALLERGICO, EASY)
- 2 Lato resina elastica bugnata a zone di portata differenziata
Elastic resin side, processed in differential capacity areas
- 3 Carenatura perimetrale antiaffossamento
Perimetral enforcement against sinking
- 4 Molle insacchettate indipendenti a 7 zone
Independent pocketed springs with 7 zones

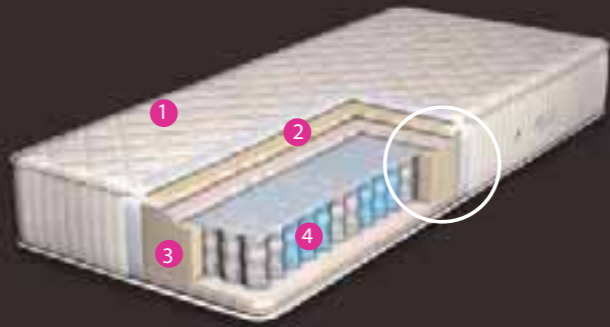

STRUTTURA
Frame

800 molle insacchettate indipendenti
800 independent pocketed springs

ALTEZZA
Height 24 cm

FODERA SFODERABILE
Removable cover SILVER CLIMA ALOE, ANALLERGICO, EASY

MANUTENZIONE FODERA
Cover care FISSO SILVER CLIMA ALOE, ANALLERGICO, EASY

MISURE SPECIALI
Custom dimensions ✓

BABILONIA

- 1 Fodere a scelta (FISSO, SILVER CLIMA ALOE, ANALLERGICO, EASY)
Linings to choose (FISSO, SILVER CLIMA ALOE, ANALLERGICO, EASY)
- 2 Lato in memory foam di grosso spessore (5cm c.a.)
Side thick of memory foam (5 cm c.ca)
- 3 Lato in resina elastica lavorata a zone di portata differenziata
Elastic resin side, processed in differential capacity areas
- 4 Carenatura perimetrale antiaffossamento
Perimetral enforcement against sinking
- 5 Molle biconiche Bonnel
Bonnel bioconical springs

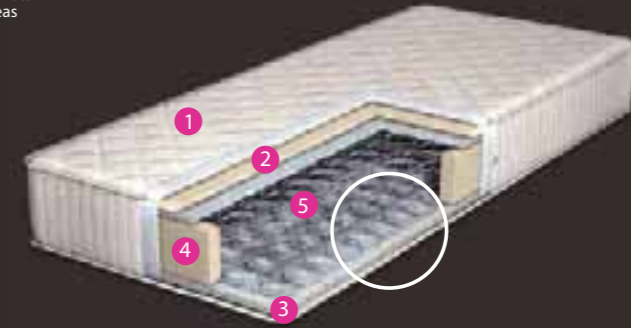

STRUTTURA
Frame

materasso a 600 molle tradizionali, molleggio High Density
mattress with 600 spring and high density springing system

ALTEZZA
Height 24 cm

FODERA SFODERABILE
Removable cover SILVER CLIMA ALOE, ANALLERGICO, EASY

MANUTENZIONE FODERA
Cover care FISSO SILVER CLIMA ALOE, ANALLERGICO, EASY

MISURE SPECIALI
Custom dimensions ✓

BODRUM

- 1 Fodere con trattamento ACTIGARD
Linings with ACTIGARD system
- 2 Imbottitura fibra misto lana/cotone
Upholstery in poly wool/cotton fibre
- 3 FISIO-TECH, box system antiaffossamento
FISIO-TECH, box system t against sinking
- 4 Molle ortopediche biconiche Bonnel
Bonnel bioconical springs with orthopaedic properties

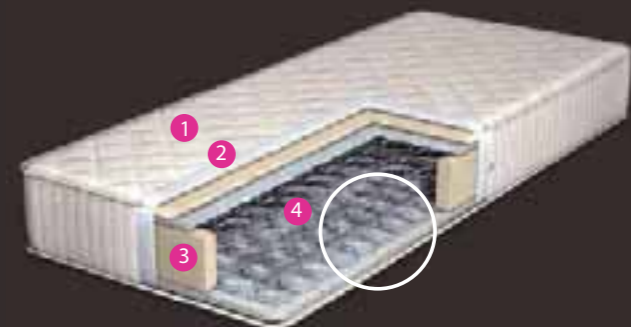

STRUTTURA
Frame

materasso a 400 molle ortopediche con molleggio Bonnel bionico
mattress with 400 springs and orthopaedic properties

ALTEZZA
Height 22 cm

FODERA SFODERABILE
Removable cover -

MANUTENZIONE FODERA
Cover care FISSO

MISURE SPECIALI
Custom dimensions ✓

ARISTON

- 1 Struttura a scelta fra:
LATTICE, MEMORY FORM, POLIURETANO,
MOLLE, MOLLE INDIPENDENTI
- 2 Fodera a scelta in base alla struttura preferita
LATTICE, MEMORY, POLIURETANO --> ANALLERGICO/EASY
MOLLE --> FISSO
MOLLE INDIPENDENTI --> EASY

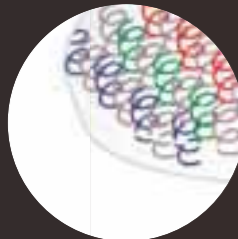

cfr. EFESO



cfr. BODRUM



cfr. GIZA



cfr. CORFU'



cfr. EGITTO

STRUTTURA Frame

A scelta tra LATTICE, MEMORY FORM, POLIURETANO, MOLLE, MOLLE INDIPENDENTI
Mattress to choose (NATURAL LATEX, MEMORY, VISCOELASTIC FOAM, SPRINGS, POCKET SPRINGS)

ALTEZZA Height	variabile / changeable (19-24 cm)
FODERA SFODERABILE Removable cover	ANALLERGICO, EASY
MANUTENZIONE FODERA Cover care	FISSO     ANALLERGICO, EASY    
MISURE SPECIALI Custom dimensions	—

BOX SPRING VIP

- 1 Topper in piuma
Feather topper
- 2 Materasso
Mattress
- 3 Sommier con Box Spring Vip
Sommier with Box Spring Vip

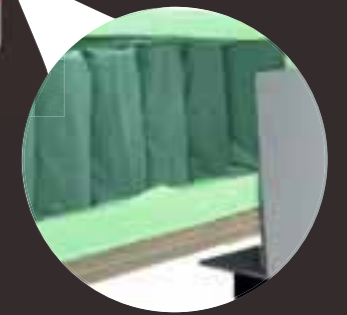

3 STRUTTURA Frame

Struttura composta da accoppiato incollato su pannello in legno multistrato fresato e box antisfondamento
MOLLE INDIPENDENTI o MOLLE BONNEL ORTOPEDICHE
Frame made by paired stuck on milled multilayered wood and box shatterproof
POCKET SPRINGS or ORTHOPEDICAL BONNEL SPRINGS

ALTEZZA Height	15 cm
FODERA SFODERABILE Removable cover	—
MANUTENZIONE FODERA Cover care	FISSO    
MISURE SPECIALI Custom dimensions	✓ Adattabile a tutti i letti indicati a listino Available for all bed in the price's list

“ — The best sleeping plan. ”

Relax

Grazie ai suoi ravvicinati interspazi tra le doghe e soprattutto in prossimità di testa e piedi, è l'ideale supporto per materassi "morbidi". Le doghe provviste di regolazione di rigidità ottimizzano, grazie alla maggiore elasticità, la personalizzazione del singolo piano letto.

Thanks to the close spaces between the slats, becomes an ideal support for all "soft" mattresses. The slats provided with rigidity regulation, optimize the personalization of each single sleeping surface, through their higher elasticity.



Relax singola

- Sistema monodoga da 68 mm inserite nel telaio.
- Regolatori di rigidità per la zona lombare.
- Misure disponibili (cm):
- 90 x 200
- 120 x 200

Relax single

- Testo inglese
- Available measures (cm):
- 90 x 200
- 120 x 200

Relax matrimoniale

- Sistema monodoga da 68 mm inserite nel telaio.
- Regolatori di rigidità per la zona lombare.
- Misure disponibili (cm):
- 140 x 200
- 153 x 203
- 160 x 200
- 180 x 200
- 193 x 203

Relax matrimoniale

- Testo inglese
- Available measures (cm):
- 140 x 200
- 153 x 203
- 160 x 200
- 180 x 200
- 193 x 203

Confort

Scegliere un supporto anatomico in legno significa scegliere un prodotto che unisce l'elevato pregio estetico alle proprietà naturali dei componenti, con vantaggi sempre più riconosciuti e apprezzati, dall'azione antistatica a quella anti umidità. Una soluzione che oggi costituisce il perfetto complemento a materassi di qualità, grazie a un equilibrato accoppiamento che mantiene la corretta postura della colonna vertebrale anche durante il sonno.

By choosing a wooden anatomic bed support you choose a product, that matches high aesthetic value and natural properties of components, with the more and more known and appreciated advantages, from antistatic action to anti-dampness. A solution making up a perfect complement for quality mattresses, thanks to a balanced matching that keeps the correct posture of the spinal column also during one's sleep.



Confort base

- Sistema multidoga da 38 mm a copertura totale.
- Regolatori di rigidità per la zona lombare.
- Misure disponibili (cm):
- 90 x 200
- 160 x 200*
- 180 x 200**

Confort base

- Testo inglese
- Available measures (cm):
- 90 x 200
- 160 x 200*
- 180 x 200**

Confort motorizzata

- Sistema multidoga da 38mm a copertura totale.
- Piano riposo a 4 snodi.
- Doppia motorizzazione.
- Regolatori di rigidità per la zona lombare.
- Misure disponibili (cm):
- 90 x 200
- 160 x 200*
- 180 x 200**

Confort motorizzata

- Testo inglese
- Available measures (cm):
- 90 x 200
- 160 x 200*
- 180 x 200**

*: Rete formata da 2 reti singole da 80x200. **: Rete formata da 2 reti singole da 90x200.

Letti Collezione 019

*Racconti di stile.
Delicati, armoniosi, eleganti.*

*Stories of style.
Delicate, harmonious, elegant.*

Index

Sartorial Beauty and Delicate Elegance

History	5
Bow	7
Frida	15
Moire	25
Annie	33
Sommier Major	41
Lucrezia	49
Roy	59
Freddy	77
Andy	87
Pablo	95
Technical	103



History

Sartorial Beauty and Delicate Elegance

Dalla perfetta sintonia tra tradizione e contemporaneità, nasce Chaarme. Azienda italiana, espressione del Made in Italy autentico. Sapienti mani artigiane cuciono tessuti pregiati e pelli ricercate per trasformare le idee in progetti. Professione e alta qualità insieme garantiscono creazioni uniche, capaci d'affiancare un'eleganza senza tempo a uno stile raffinato.

La quotidianità è fatta di gesti semplici portatori di stile e benessere negli ambienti; le forme e i colori che scegliamo rendono accoglienti gli spazi in cui viviamo. Le materie prime di qualità, la ricerca continua, la cura dei particolari sono i dettagli che rendono eccellente ogni lavorazione.

Un'azienda all'avanguardia, capace di interpretare le tendenze del momento che affianca allo sviluppo tecnologico, una capacità manuale che si traduce nel lavorare pelli e tessuti selezionati di qualità.

L'alta professionalità permette di soddisfare ogni desiderio del cliente e di trasformarlo in realtà.

Racconti di stile vi faranno scoprire città diverse, ognuna con le proprie caratteristiche, la propria storia e le proprie passioni da raccontare.

Noi abbiamo trasformato queste emozioni e le abbiamo reinterpretate con i nostri prodotti.

Chaarme is born from the perfect harmony between tradition and modernity. Italian company, it embodies the authentic Made in Italy concept. Well-trained artisans use precious fabrics and refined leathers to transform the ideas in projects. Professionalism and high quality together guarantee the creation of unique pieces of furniture that can match a timeless elegance with a refined style.

Daily life is made of simple gestures that bring joy and well-being in the ambiances; shapes and colours that we choose create welcoming rooms to live in.

High quality materials, continuous research and attention on details are the features that allow creating excellent workmanship. A leading company, able to interpret the current trends and to combine technological instruments and skillful workmanship in order to transform quality selected leathers and fabrics into exclusive pieces of furniture.

The high professionalism allows to satisfy every desire and to transform any customer's request into reality.

Stories of style will make you discover different cities, each with its own characteristics, its own history and its emotions to tell. We have transformed these stories into style and reinterpreted them with our products.



Bow

Design Luca Piccinno

(...) la luce, è quasi l'unica cosa di cui non posso assolutamente fare a meno: la luminosità di un cielo sereno.

Al che sono subito partito per Nizza. (Friedrich Nietzsche)

La luce penetra dalle grandi finestre, diffonde contemporanea eleganza e valorizza le lavorazioni artigianali.

(...) light is almost the only thing I absolutely can not do without: the brightness of a clear sky.

And I left immediately for Nizza. (Friedrich Nietzsche)

The light breaks in through the large windows, diffuses contemporary elegance and enhances the handmade details.





Poltrona Dolce Vita in tessuto Bruges colore 900.
Dolce Vita chair in fabric Bruges colour 900.





In primo piano tessuto Malibù colore 1 con ricamo e dettaglio fiocco nero.
In foreground Bow bed in fabric Malibù, colour 1, with black embroidery and tassel.





Frida

Design Luca Piccinno

Una passeggiata a Parigi vi fornirà lezioni di storia, bellezza
e visione della vita. (Thomas Jefferson)

L'armonia dei dettagli borghesi, la cura dei particolari e la raffinatezza delle finiture rendono l'ambiente
caldo e armonioso.

A walk in Paris will provide you with lessons of history, beauty
and vision of life. (Thomas Jefferson)

The harmony of exclusive elements, the attention to details and the refinement of the finishes make
the room warm and harmonious.





Comodino Alicia con struttura in metallo cromato lucido e piano in marmo di Carrara.
Side table Alicia with metal structure in polished chrome finish and Carrara marble top.



Giroletto e retro testiera in Nabuk color Sabbia, frontale in tessuto Malta colore 1.
Struttura in noce Canaletto.
Bed frame and headboard back in Sand-coloured Nubuck, headboard front in fabric
Malta colour 1. Structure in Canaletto walnut.





Dormeuse Dolcevita in tessuto Formentera colore 143.
Dolce Vita dormeuse in fabric Formentera colour 143.



Moire

...il Duomo di Milano. Questa chiesa, rischiarata da una bella luna, offre uno spettacolo di bellezza straordinaria ed unica al mondo.

L'architettura non mi ha mai offerto simili sensazioni. (Stendhal)

Forme razionali s'accompagnano a linee decise e rendono l'ambiente discreto e, insieme, affascinante.

... the Milan Cathedral. This church, brightened by a beautiful moon, offers a sight of extraordinary beauty, unique in the world.

Architecture has never offered me such feelings. (Stendhal)

Rational shapes accompany strong lines and make the environment discreet and fascinating at the same time.





Letto Moire in tessuto Monaco colore 666.

Comodino Pop con struttura in metallo cromato lucido e piano in vetro color corda.

Moire bed in fabric Monaco colour 666.

Pop side table with metal structure in polished chrome finish and glass top in ecru colour.



Comodino Pop con struttura in metallo cromato lucido e piano in vetro color corda.
Pop bedside table with metal structure in polished chrome finish and glass top in ecru colour.



Annie

Roma, bellezza disarmante (...) la festosità dei suoi giardini e la magnificenza delle grandi terrazze; e le sue notti, così lunghe, silenziose e colme di stelle. (Rainer Maria Rilke)

Un'atmosfera riservata avvolge la camera, dettagli classici e imbottiti generosi trasmettono ospitalità.

Rome, disarming beauty (...) the festivity of its gardens and the magnificence of the great terraces; and his nights, so long, silent and full of stars. (Rainer Maria Rilke)

A cosy atmosphere envelops the bedroom, classic details and huge upholstered furniture lend a sense of hospitality.





Letto Annie in tessuto Porto colore 26.
Poltrona Audrey in pelle Panama colore 5502.
Separé Misaki in tessuto Granada colore 15 e struttura colore grigio avio (pag. seguente).
Annie bed in fabric Porto colour 26.
Audrey armchair in leather Panama colour 5502.
Misaki screen in fabric Granada colour 15 and structure in avio grey colour (next page).







Sommier Major

Lecce, l'immenso piano della campagna, leggermente ondulato, il mare così maestoso, il cielo così infinito e sereno costituiscono una trinità grandiosa e singolare. (Paul Schubring)

I profumi della natura, la delicatezza delle nuances terra, i richiami alla semplicità diffondono armonia.

Lecce, the limitless countryside, slightly wavy, the majestic sea and the infinite and serene sky constitute a grandiose and singular trinity.

(Paul Schubring)

Scents of nature and the delicacy of earth nuances recall to simplicity and spread harmony.





Letto Soggiorno in tessuto Tulum colore 782.
Soggiorno bed in fabric Tulum colour 782.







Lucrezia

Anversa, la Signora. Conosciuta come la Regina dei Diamanti, è sontuosa, impostata e insieme discreta. (Autore Anonimo)

Colori caldi, dettagli naturali e superfici materiche trasformano lo sfarzo e la rigidità in raffinata eleganza.

Antwerp, the lady. Known as the Queen of Diamonds, is sumptuous, impeccable and modest at the same time. (Autore Anonimo)

Warm colours, natural details and solid surfaces transform magnificence and stiffness in refined elegance.







Letto Lucrezia in tessuto Malibu colore 106.
 Comodini Provenza in faggio laccato.
 Poltrona Venus in tessuto Malibu colore 101 e struttura in noce nazionale tinto.
 Lucrezia bed in fabric Malibu colour 106.
 Side tables in lacquered beechwood.
 Venus chair in fabric Malibu colour 101 and wooden structure lacquered grey colour.







Roy

Design Luca Piccinno

Santorini, isola da sentire e da amare. Il blu del mare le penetra dentro e la rende intensa. (Autore Anonimo)

Il mare, complici le tonalità pure della stanza e i dettagli nelle sfumature dell'azzurro, diventa il protagonista.

Santorini, an island to feel and to love. The blue of the sea penetrates inside and makes it intense. (Autore Anonimo)

The sea becomes the protagonist in a room with pure tones and details in the shades of light blue.





Letto Roy nella versione con cuscino in lino in tessuto Malibù colore 1 con cuciture tagliacuci colore grigio. Struttura in rovere tinto bianco poro aperto.
Roy bed with headboard cushion in linen, in fabric Malibu colour 1 with grey overlock stitching. Structure in ash solid wood lacquered in white open pore finish.







Sdraio Saint Tropez con struttura in iroko laccato e cuscino in tessuto Malibù colore 105.
Saint Tropez lounge with structure in iroko wood and cushion in fabric Malibu colour 105.



Roy

Design Luca Piccinno

Città di prosa e fantasia, (...) le sue strade un trionfo del cubismo...
New York, più di ogni altra città, è la massima espressione della nostra
epoca moderna. (Leon Trotsky)

L'ambiente dominato dal grigio, le finiture decise e gli imbottiti in una tonalità fredda conferiscono
carattere e modernità.

City of prose and fantasy, (...) its streets a triumph of cubism ...
New York, more than any other city, is the highest expression of our
modern age. (Leon Trotsky)

The space dominated by grey colour, the bold finishes and the upholstery in a cool shade give
character and modernity.





Letto Roy nella versione con cuscino in Nabuk colore Orione taglio vivo e struttura in noce nazionale scuro.
Roy bed with headboard cushion in Nubuck colour Orione with sharp cut and solid oak structure in dark walnut finish.



Poltrona Venus in tessuto Malibù colore 101 e struttura in noce nazionale.
Pouf Keith, capitonné, tessuto Monaco colore 1.
Venus chair in fabric Malibù colour 101 and structure in walnut.
Keith pouf with capitonné quilting, in fabric Monaco colour 1.





Freddy Plus

Modernità e tradizione, tolleranza e trasgressione, biciclette, mulini a vento e capolavori d'arte. Ecco Amstedarm. (Autore Anonimo)

Lo stile rigido nelle forme, preciso nell'arredo, in armonia nelle scelte cromatiche viene scaldato da chiare e luminose sfumature.

Modernity and tradition, tolerance and transgression, bicycles, windmills and masterpieces of art. Here is Amstedarm. (Anonymous author)

A style made of rigorous shapes allows a smart furnishing and, thanks to its harmonious colours, is warmed up by clear and bright shades.





Letto Freddy in tessuto Amalfi colore 26.
Freddy bed in fabric Amalfi colour 26.







Toilette Vanilla in pelle Extra colore ferro e interni in microfibra in tinta.
Pouf Cacao in pelle Extra colore ferro.
Vanilla dressing table in leather Extra colour iron grey and internal parts in microfibre same colour.
Cacao pouf in leather Extra colour iron grey.





Andy

Oslo. La Natura Divina ci ha dato la campagna, l'arte umana ha costruito la città. (Marco Terenzio Varrone)

I confini s'annullano, il paesaggio è protagonista mentre particolari razionalisti definiscono gli spazi.

Oslo, Divine Nature gave the fields, human art built the cities.
(Marco Terenzio Varrone)

Bordelines disappear, landscape is the main characted while rational details define the spaces.





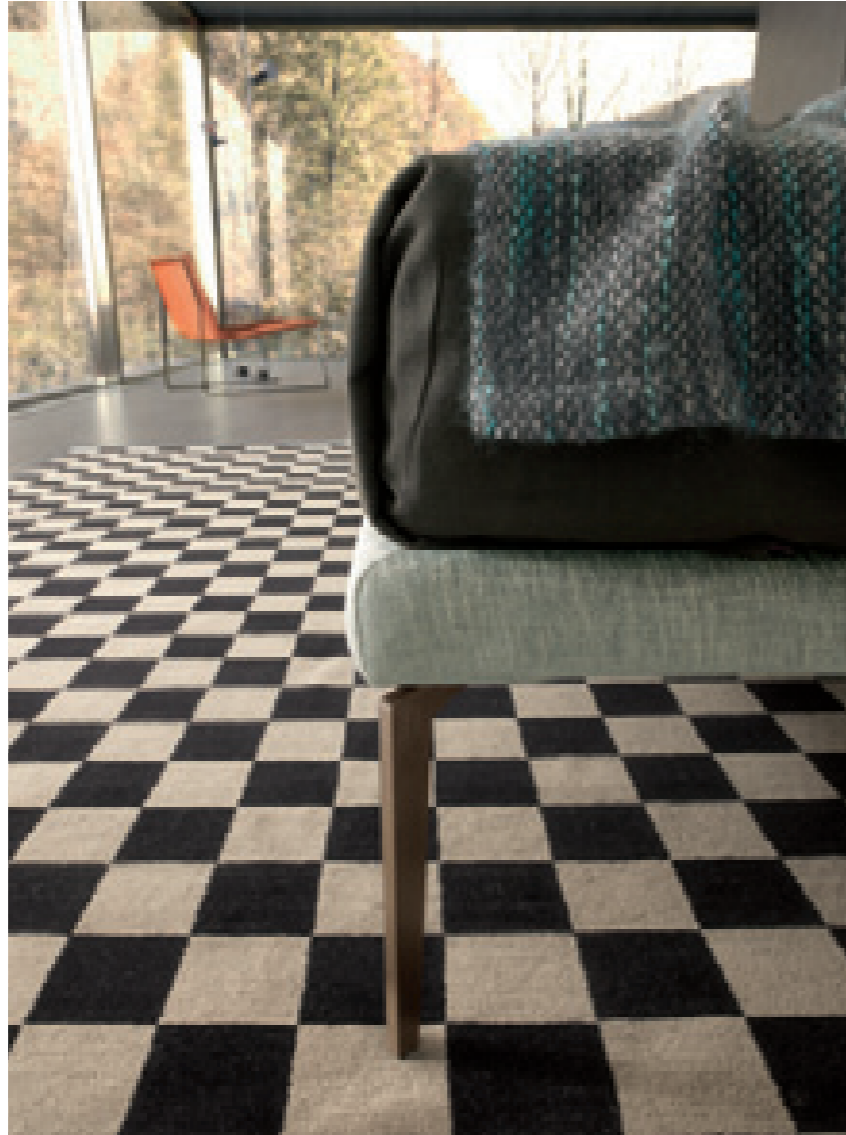

Letto Andy in tessuto Flamingo colore 7 con dettaglio del piede brunito.
Poltrona Silence in Nabuk color terra e basamento brunito.
Andy bed in fabric Flamingo colour 7 with brownish feet.
Silence chair in earth-coloured Nubuck and brownish base.





Pablo

New York, la visione di una grande metropoli, palpitante di vita incessante, che batte al ritmo di un cuore immenso.
(Theodore Dreiser)

Un ambiente morbido e armonioso, ricco di dettagli dove ogni particolare racconta con stile la sua storia.

New York, the vision of a great metropolis, throbbing with endless life, beating to the rhythm of an immense heart.
(Theodore Dreiser)

A soft and harmonious environment, full of details where every element tells its story with style.





Letto Pablo in tessuto Porto colore 41. Cuscini ornamentali in tessuto Porto colore 41, in tessuto Roma colore 11 e tessuto Roma colore 8.
 Comodino Pop con struttura in metallo cromato lucido e piano in vetro color corda.
 Tavolino Alicia con struttura in metallo cromato lucido e piano in marmo di Carrara.
 Poltrona Silence in Nabuk colore terra e basamento satinato.
 Pablo bed in fabric Porto colour 41. Decorative cushions in fabric Porto colour 41, in fabric Roma colour 11 and 8.
 Pop bedside table with metal structure in polished chrome finish and glass top in ecrù colour.
 Alicia little table with metal structure in polished chrome finish and Carrara marble top.
 Silence chair in earth-coloured Nabuk and structure in satinized finish.





Technical



Annie Plus

Letto con testata curva dall'elegante rivestimento a balza e spacchi laterali in tessuto Smeraldo colore 106. Completamente sfoderabile.
 Bed with rounded headboard and elegant cover with split-corner skirt in fabric Smeraldo colour 106. Completely removable cover.



Sommier
 tessuto Cordoba colore 6
 fabric Cordoba colour 6



Sommier Plus
 tessuto Tropea colore 31
 fabric Tropea colour 31



Freddy
 tessuto Azzorre colore 3
 fabric Azzorre colour 3



Pablo

Confortevole divano letto disponibile in moduli diversi, componibile in modo da creare un originale sistema di sedute. Rivestimento completamente sfoderabile in tessuto Porto colore 41.
Comfortable sofa bed available in many models that can be matched to create an original seat modular system. Completely removable cover in fabric Porto colour 41.



Bow Design Luca Piccinno

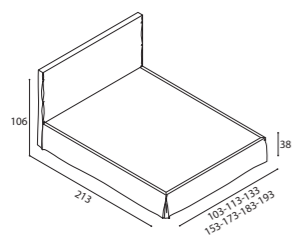

Frida Design Luca Piccinno

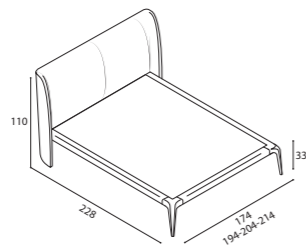

Moire

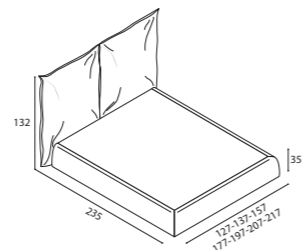

Freddy

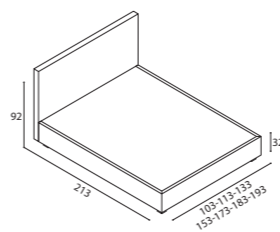

Freddy Plus

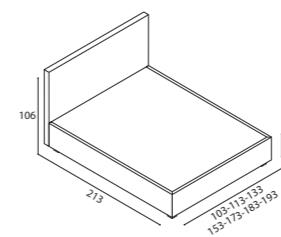

Andy

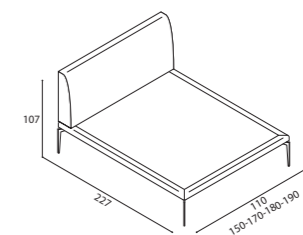

Annie

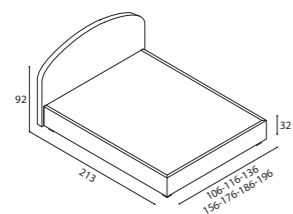

Annie Plus

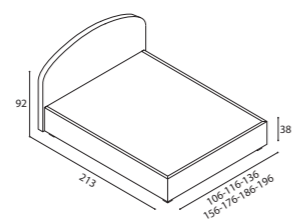

Sommiera Major

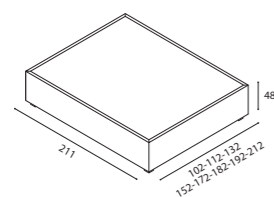

Sommier

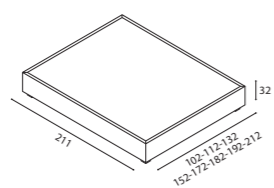

Sommier Plus

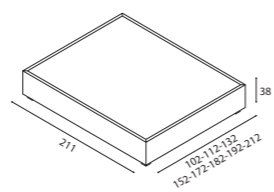

Pablo

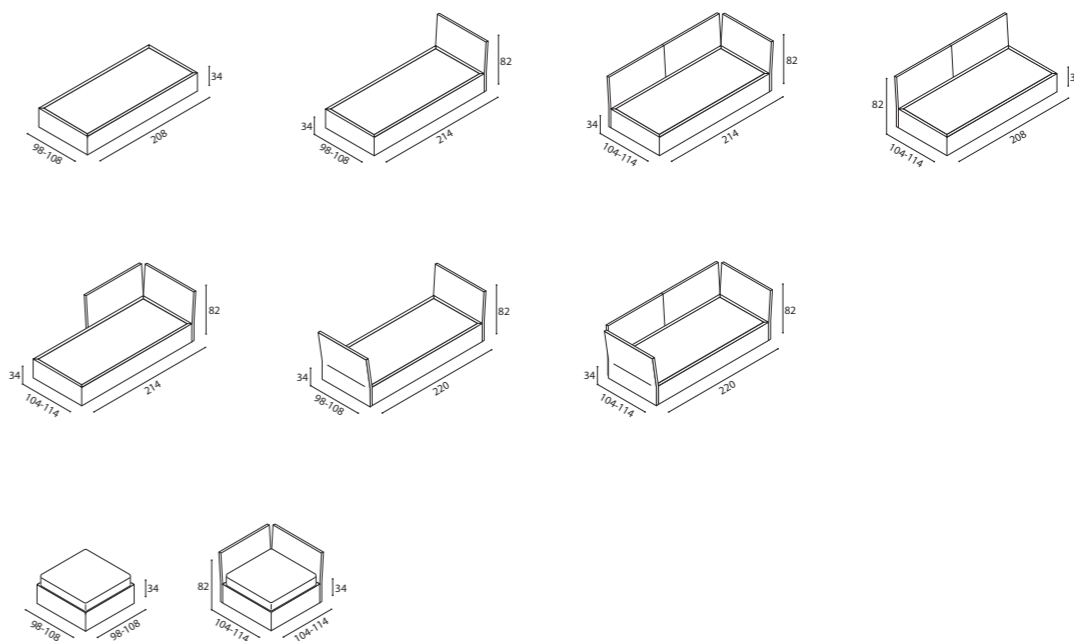

Lucrezia

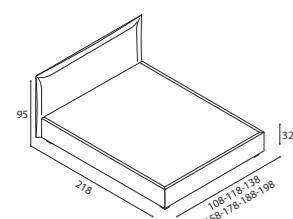

Roy Design Luca Piccinno

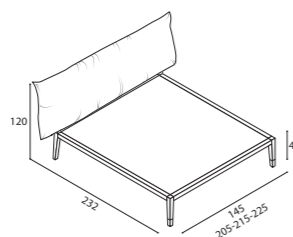



Pouf Pablo in tessuto Smeraldo colore 136.
Pablo pouf in fabric Smeraldo colour 136.



Pouf Urban in tessuto Ronda colore 49.
Urban pouf in fabric Ronda colour 49.



Sedia Margherita in tessuto Black Rock colore 73.
Margherita chair in fabric Black Rock colour 73.

Dolce Vita

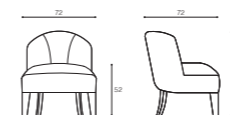

Dolce Vita

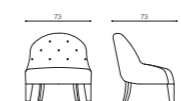

Dolce Vita dormeuse

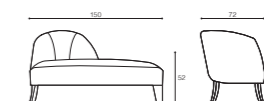

Silence



Venus



Saint Tropez

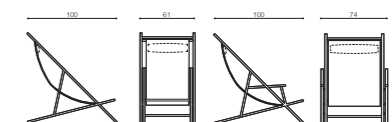

Graphic concept_
Fiorella Radice

Render images_
Ennio Furlan

Photo+Render_
GabriottiFotografi

Styling_
Carla Bernardis

Pre Press_
Imoco

Printing in Italy
Gennaio 2019
Imoco

thanks to
TineKHome image flowers page 4

Chaarme
Via Fossa Vecchia, 14/A
31018 Francenigo di Gaiarine (TV)
Tel. +39 0434 1680154
www.chaarme.com
info@chaarme.com